

7-1-2014

Development of Advanced Capillary Electrophoresis Techniques with UV and Mass Spectrometry Detection for Forensic, Pharmaceutical and Environmental Applications

Hanzhuo Fu

Florida International University, hfu001@fiu.edu

DOI: 10.25148/etd.FI14071160

Follow this and additional works at: <https://digitalcommons.fiu.edu/etd>

Recommended Citation

Fu, Hanzhuo, "Development of Advanced Capillary Electrophoresis Techniques with UV and Mass Spectrometry Detection for Forensic, Pharmaceutical and Environmental Applications" (2014). *FIU Electronic Theses and Dissertations*. 1531.
<https://digitalcommons.fiu.edu/etd/1531>

This work is brought to you for free and open access by the University Graduate School at FIU Digital Commons. It has been accepted for inclusion in FIU Electronic Theses and Dissertations by an authorized administrator of FIU Digital Commons. For more information, please contact dcc@fiu.edu.

FLORIDA INTERNATIONAL UNIVERSITY

Miami, Florida

DEVELOPMENT OF ADVANCED CAPILLARY ELECTROPHORESIS
TECHNIQUES WITH UV AND MASS SPECTROMETRY DETECTION FOR
FORENSIC, PHARMACEUTICAL AND ENVIRONMENTAL APPLICATIONS

A dissertation submitted in partial fulfillment of

the requirements for the degree of

DOCTOR OF PHILOSOPHY

in

CHEMISTRY

by

Hanzhuo Fu

2014

To: Interim Dean Michael R. Heithaus
College of Arts and Sciences

This dissertation, written by Hanzhuo Fu, and entitled Development of Advanced Capillary Electrophoresis Techniques with UV and Mass Spectrometry Detection for Forensic, Pharmaceutical and Environmental Applications, having been approved in respect to style and intellectual content, is referred to you for judgment.

We have read this dissertation and recommend that it be approved.

Yong Cai

David Chatfield

Chenzhong Li

J. Martin E. Quirke

Bruce R. McCord, Major Professor

Date of Defense: July 1, 2014

The dissertation of Hanzhuo Fu is approved.

Interim Dean Michael R. Heithaus
College of Arts and Sciences

Dean Lakshmi N. Reddi
University Graduate School

Florida International University, 2014

© Copyright 2014 by Hanzhuo Fu

© Copyright 2014 John Wiley and Sons, Ltd.

Merola, G.[#], Fu, H.[#] ([#] co-first authors), Tagliaro, F., Macchia, T., and McCord, B. R.,

Chiral separation of 12 cathinone analogs by cyclodextrin-assisted capillary electrophoresis with UV and mass spectrometry detection. *Electrophoresis*, 2014.

DOI 10.1002/elps.201400077.

All rights reserved.

DEDICATION

To my wife Cen, and my parents. I couldn't have done this without you.

May the world stay at peace.

献给

我的妻子，和我的父母。没有你们，我无法做到这一切。

愿世界和平。

ACKNOWLEDGMENTS

First and foremost, I would like to thank my advisor, Dr. Bruce R. McCord, for providing me the opportunity to be a part of his research group and for his help, support and encouragement. I would never achieve my academics goals without his patience and faith in me. I will always be grateful for his mentorship.

I would extend my thanks to my dissertation committee members, Dr. Yong Cai, Dr. David Chatfield, Dr. Chenzhong Li, and Dr. J. Martin E. Quirke, for their advice given to the project and to my Ph.D. study. Special thanks for Dr. Quirke for his assistance on the organic part of this work.

I want to thank Jennifer Thomas, Inge Corbin, and Chloe De Perre for their tutorial and assistance on the monolith project, Gustavo Merola for his collaboration on the chiral separation project, and Bingxue Zheng for her cooperation on the microcystin analysis project. I would also like to thank all the previous and current members of Dr. McCord's research group.

I gratefully acknowledge the faculty and staff in the Department of Chemistry & Biochemistry at FIU. Special thanks to Dr. Alexander Mebel and Dr. Xiaotang Wang. Also, I would like to thank my wife for her encouragement and support during my PhD study at FIU, and my family and friends in China, who gave me love, support, and power.

Graduate teaching assistant was supported by University Graduate School and Department of Chemistry. Conference travel funding was provided by College of Arts & Sciences and Graduate and Professional Student Committee (GPSC).

I truly thank all of you from the bottom of my heart.

I guess I could plan a trip to Paris?! ☺

ABSTRACT OF THE DISSERTATION

DEVELOPMENT OF ADVANCED CAPILLARY ELECTROPHORESIS TECHNIQUES WITH UV AND MASS SPECTROMETRY DETECTION FOR FORENSIC, PHARMACEUTICAL AND ENVIRONMENTAL APPLICATIONS

by

Hanzhuo Fu

Florida International University, 2014

Miami, Florida

Professor Bruce R. McCord, Major Professor

Capillary electrophoresis (CE) is a modern analytical technique, which is electrokinetic separation generated by high voltage and taken place inside the small capillaries. In this dissertation, several advanced capillary electrophoresis methods are presented using different approaches of CE and UV and mass spectrometry are utilized as the detection methods.

Capillary electrochromatography (CEC), as one of the CE modes, is a recent developed technique which is a hybrid of capillary electrophoresis and high performance liquid chromatography (HPLC). Capillary electrochromatography exhibits advantages of both techniques. In Chapter 2, monolithic capillary column are fabricated using in situ photoinitiation polymerization method. The column was then applied for the separation of six antidepressant compounds.

Meanwhile, a simple chiral separation method is developed and presented in Chapter 3. Beta cyclodextrin was utilized to achieve the goal of chiral separation. Not only twelve cathinone analytes were separated, but also isomers of several analytes were

enantiomerically separated. To better understand the molecular information on the analytes, the TOF-MS system was coupled with the CE. A sheath liquid and a partial filling technique (PFT) were employed to reduce the contamination of MS ionization source. Accurate molecular information was obtained.

It is necessary to propose, develop, and optimize new techniques that are suitable for trace-level analysis of samples in forensic, pharmaceutical, and environmental applications. Capillary electrophoresis (CE) was selected for this task, as it requires lower amounts of samples, it simplifies sample preparation, and it has the flexibility to perform separations of neutral and charged molecules as well as enantiomers.

Overall, the present work demonstrates the versatility of capillary electrophoresis methods in forensic, pharmaceutical, and environmental applications.

TABLE OF CONTENTS

CHAPTER	PAGE
CHAPTER 1 GENERAL INTRODUCTION	1
1.1 Historical Background	1
1.2 Principles of Separation in Capillary Electrophoresis	3
1.3 Significance of the Work	10
CHAPTER 2 MONOLITHIC CAPILLARY ELECTROCHROMATOGRAPHY FOR THE TRICYCLIC ANTIDEPRESSANTS.....	13
2.1 Introduction.....	13
2.1.1 Introduction of the project	13
2.1.2 Background and significance of capillary electrophoresis and capillary electrochromatography	15
2.2 Experimental.....	20
2.2.1 Chemicals and materials	20
2.2.2 Instrumentation	22
2.2.3 Monolithic capillary preparation.....	23
2.2.4 Sample preparation	25
2.2.5 Liquid-liquid extraction	26
2.3 Results and Discussion	26
2.3.1 Monolithic columns	26
2.3.2 Method development and CEC-UV results	28
2.3.3 Liquid-liquid extraction and spiked urine sample	34
2.4 Concluding Remarks.....	37
CHAPTER 3 CHIRAL SEPARATION OF CATHINONE ANALOGS BY CYCLODEXTRIN-ASSISTED CAPILLARY ELECTROPHORESIS	38
3.1 Introduction.....	38
3.2 Experimental.....	44
3.2.1 Chemicals.....	44
3.2.2 Instrumentation	47
3.3 Results and Discussion	48
3.3.1 Method development and CE-UV results	48
3.3.1.1 Background electrolyte (BGE) optimization	49
3.3.1.2 CE-UV results.....	55
3.3.2 Method validation	57
3.4 Concluding Remarks.....	59
CHAPTER 4 IDENTIFICATION OF CATHINONE ANALOGS BY TIME-OF- FLIGHT MASS SPECTROMETRY	60
4.1 Introduction.....	60
4.2 Experimental.....	62
4.2.1 Chemicals and materials	62

4.2.2 Background electrolyte preparation	63
4.2.3 Sample preparation	64
4.2.4 Instrumentation	64
4.3 Results and Discussion	66
4.3.1 Method development and CE-MS results	66
4.3.1.1 Buffer selection	66
4.3.1.2 Optimization of MS conditions	70
4.3.1.3 Partial-filling (PF) technique	71
4.3.1.4 TOF-MS results	72
4.3.2 Analysis of seized drug samples	76
4.4 Concluding Remarks	78
CHAPTER 5 MICROCYSTIN AND CAPILLARY ELECTROPHORESIS MASS SPECTROMETRY: AN ENVIRONMENTAL APPLICATION	80
5.1 Introduction	80
5.1.1 Cynobacteria and microcystin	80
5.1.2 Current analytical approaches for microcystin detection	83
5.2 Experimental	85
5.2.1 Chemicals and materials	85
5.2.2 Instrumentation	85
5.3 Results and Discussion	86
5.3.1 Volatile buffer consideration for MS detection	87
5.3.2 TOF-MS results	87
5.4 Concluding Remarks	89
CHAPTER 6 OVERALL CONCLUSIONS	90
CHAPTER 7 FUTURE RESEARCH ON FORENSIC, ENVIRONMENTAL AND PHARMACEUTICAL APPLICATIONS BY ADVANCED CAPILLARY ELECTROPHORESIS TECHNIQUES	93
7.1 Monolithic Chiral Stationary Phase	93
7.2 Monolithic CEC Microchips	95
7.3 Capillary Zone Electrophoresis for Chiral Separation	97
LIST OF REFERENCES	100
APPENDICES	112
VITA	123

LIST OF TABLES

TABLE	PAGE
Table 2.1 Chemical components of monolithic mixture.....	21
Table 2.2 ESI-TOF-MS experiment conditions for analysis of spiked urine samples	23
Table 2.3 Effect of voltage and duration of injection on peaks. Values are given as percentages in relation to the value for 5 kV – 10 s injections	31
Table 2.4 Figures of merit for the CEC-UV results ($n \geq 5$).....	34
Table 2.5 Accurate mass measurements of extracted urine samples ($n \geq 5$).....	37
Table 3.1. Figures of merit for the CE-UV results of the chiral separation project.....	58
Table 4.1 CE-ESI-TOF-MS parameters for chiral analysis of cathinone analogs.....	65
Table 4.2 Effect of amount of HS- γ -CD filled in the capillary on peaks. Values are given as percentage in relation to the value for 70% (56 cm) partial filling	69
Table 4.3 CE-ESI-TOF-MS accurate mass measurements for chiral analysis of cathinone analogs.....	75
Table 4.4 Figures of merit for the CE-ESI-TOF-MS results	76
Table 5.1 Accurate mass measurements of three microcystin analytes.....	89

LIST OF FIGURES

FIGURE	PAGE
Figure 1.1 Literature published between 1983 and 2013 on the topic of Capillary Electrophoresis using capillary electrophoresis as the key work to conduct the search. Data source: Scifinder database.....	3
Figure 1.2 Schematic diagram of the capillary electrophoresis system.....	4
Figure 1.3 Formation of the electroosmotic flow from the double layer inside the capillary.....	6
Figure 1.4 Mechanism of separations in capillary electrophoresis systems. The combination of electrophoretic mobility μ_{ep} and electroosmotic flow μ_{eo} determines the flow velocity of the eluents in the capillary.....	7
Figure 1.5 A comparison between electroosmotic flow and laminar flow. Laminar flow results in increased diffusion and band broadening and is a characteristic of HPLC separations while the flat flow profile of the EOF improves separation efficiency in CE ..	8
Figure 1.6 CE sample stacking and sample injection. Top: the analyte is injected. Middle: high voltage filed (up to 30 kV) is applied and since the electric potential difference exists, the samples are pushed towards the cathode end. Bottom: the sample ions are stacked and migrating though the capillary as a zone that is narrower than the sample injected.....	9
Figure 1.7 Trends in drug use from 2006 to 2011. Date source: the World Drug Report 2013, UNODC.	11
Figure 2.1 Schematic diagram of the CEC system	16
Figure 2.2 Comparison of electrophoresis, electrochromatography and chromatography	18
Figure 2.3 Structures of analytes used in Chapter 2	19
Figure 2.4 Monolithic column preparation procedure	25
Figure 2.5 Comparison of effective and non-effective monolithic capillary columns	29
Figure 2.6 Scanning electron micrographs of hexyl acrylate monolithic column. Entire capillary (top) and enlargement (bottom)	30
Figure 2.7 CE-UV separations using monolithic capillary columns at different pH conditions. Sample: a mixture of 6 antidepressants at 5 $\mu\text{g}/\text{mL}$. BGE: ACN:Phosphate	

Buffer 30:70. Peak identification: Desipramine (1); Cyclobenzaprine (2); Citalopram (3); Imipramine (4); Doxepin (5); Fluoxetine (6)	32
Figure 2.8 Electropherogram of separation of a mixture of six compounds at 50 ng/mL. BGE: ACN:Phosphate Buffer 30:70. Run voltage: 30 kV. Injection: 5 s at 10 kV. Cassette temperature: 25 °C. Peak identification: Desipramine (1); Cyclobenzaprine (2); Citalopram (3); Imipramine (4); Doxepin (5); Fluoxetine (6).	33
Figure 2.9 Electropherogram of TOP: Blank urine sample and BOTTOM: spiked urine sample of a mixture of three compounds at 100 ng/mL. BGE: ACN:Phosphate Buffer 30:70. Run voltage: 30 kV. Injection: 5 s at 10 kV. Cassette temperature: 25 °C.	35
Figure 2.10 Mass spectrum of spiked urine sample of a mixture of three compounds at 100 ng/mL. Three compounds were identified by TOF-MS	36
Figure 3.1a Structure of cathinone.....	39
Figure 3.1b Structures of all cathinones used in Chapter 3	39
Figure 3.2 TOP: The structure of β -cyclodextrin from top view and BOTTOM: Side view with diameter and height values of β -cyclodextrin molecule.	42
Figure 3.3 Effect of pH value on the separation of the twelve synthetic cathinones. (a) pH 2.5; (b) pH 3.5; (c) pH 5.0; (d) pH 7.0. Conditions: BGE 100 mM phosphate buffer; voltage injection, 10 kV for 10 sec; applied voltage, 25 kV; temperature, 25 °C; fused-silica capillary, 57.5 cm (49.0 cm effective length) x 50 μ m i.d.; detection, 206 nm.....	51
Figure 3.4 Effect of the concentration of β -cyclodextrine on the separation of the twelve cathinones and enantiomers. (a) 5 mM, (b) 10 mM; (c) 15 mM and (d) 20 mM. Separation conditions as in Figure 3.3.....	52
Figure 3.5 Effect of the organic modifier as an addition to the phosphate buffer on the separation of the twelve cathinones and enantiomers. Separation conditions as in Figure 3.3.....	53
Figure 3.6 Effects of concentration of β -CD and HS- β -CD on the separation of the twelve cathinones and enantiomers. Separation conditions as in Figure 3.3.....	54
Figure 3.7 Electropherogram of the simultaneous chiral separation of a mixture of 12 compounds at 100 ng/mL, using a 100 mM phosphate buffer adding with 10 mM of β -cyclodextrin. Separation conditions as in Figure 3.6. Peak identification: 4-Fluoromethcathinone (1); Dimethylcathinone (2,2'); Ethcathinone (3,3'); Buphedrone (4,4'); Pentedrone (5,5'); Methedrone (6); Methylone (7,7'); Mephedrone (8,8'); Ethylone (9,9'); 3,4-DMMC (10,10'); Pentylone (11,11'); MDPV (12,12').	56

Figure 4.1 Schematic view PF-MEKC (B) Background electrophoresis buffer; (S) surfactant in background electrophoresis buffer.....	61
Figure 4.2 Buffer selection: ammonium acetate vs. phosphate.....	68
Figure 4.3 Different partial filling percentage (length of buffer filled in capillary divided by total length of capillary).....	71
Figure 4.4 Extracted Ion Chromatograms at specific m/z of a mixture of 12 cathinone analytes at 0.5 µg/mL each using 50 mM pH 2.5 phosphate buffer with 0.6% (v/v) highly sulfated-γ-cyclodextrin, TOF-MS conditions: source temperature = 250 °C, drying gas = 5 mL/min, nebulizer pressure = 10 psig, positive ion mode (ESI+), capillary = 3000 V, fragmentor = 125 V, skimmer = 40 V. Peak identification: 4-Fluoromethcathinone (1,1'); Dimethylcathinone (2); Ethcathinone (3); Buphedrone (4); Pentedrone (5); Methedrone (6,6'); Methylone (7,7'); Mephedrone (8,8'); Ethylone (9,9'); 3,4-DMMC (10,10'); Pentylone (11,11'); MDPV (12,12').....	74
Figure 4.5 Sample A: TOF-MS Extracted Ion Chromatogram (top) and mass spectrum showing peak m/z 208.0968 (bottom).....	77
Figure 4.6 Sample B: TOF-MS Extracted Ion Chromatogram (top) and mass spectrum showing peaks m/z 192.1354 and m/z 208.0952 (bottom).....	78
Figure 5.1 The structures of some cyanobacteria.....	81
Figure 5.2 Extracted mass spectrum of MC-RR, MC-YR and MC-LR.....	88
Figure 5.3 Mass spectrum of MC-RR, MC-YR and MC-LR.....	88
Figure 7.1 Synthesis of the chemically modified chiral polysiloxanes Chirasil-Dex. DMSO = dimethyl sulfoxide, DMF = dimethylformamide, polysiloxane = methylhydro/dimethylpolysiloxane 5/95.....	94
Figure 7.2 A polymer-based monolithic CEC microchip was fabricated by Daniel J. Throckmorton, Timothy J. Shepodd, and Anup K. Singh. The structure was photoinitiated using acrylate based monomer mixture.....	96
Figure 7.3 Schematic diagram of the microchip CEC-MS configuration: (1) separation channel; (2) double-T injector; (3) ESI source; (4) eluent reservoir; (5) sample inlet reservoir; (6) sample waste reservoir; (7) eluent waste reservoir that houses the porous glass gate; (8) side channel for flushing the monolithic channel; (9) ESI emitter.....	97
Figure 7.4 Chemical structure of 18C6H4.....	98
Figure 7.5 Chemical structure of penicillin G potassium salt (PenG) used as chiral selector in Ref. [119].....	98

LIST OF EQUATIONS

EQUATIONS	PAGE
Equation 1.1 Helmholtz equation	5
Equation 1.2 Calculation of linear velocity v	5
Equation 1.3 Calculation of theoretical plates (N).....	5
Equation 1.4 Separation mechanism of the capillary electrophoresis system	6
Equation 2.1 Decomposition of 2,2'-azobisisobutyronitrile (AIBN).....	26
Equation 2.2 Monomer hexyl acrylate (HA) initiation.....	27
Equation 2.3 Monomer propagation	27
Equation 2.4 Termination of the polymerization reaction.....	28
Equation 3.1 Separation mechanism of CD proposed by Chankvetadze.....	43
Equation 3.2 Separation mechanism of CD when association constants are at the same value.....	44

ABBREVIATIONS AND ACRONYMS

ACN	Acetonitrile
AMU	Atomic Mass Unit
APCI	Atmospheric Pressure Chemical Ionization
BGE	Background Electrolyte
CD	Cyclodextrin
β -CD	Beta-Cyclodextrin
HP- β -CD	Hydroxypropyl-Beta-Cyclodextrin
HS- β -CD	Highly Sulfated-Beta-Cyclodextrin
γ -CD	Gamma-Cyclodextrin
HS- γ -CD	Highly Sulfated-Gamma-Cyclodextrin
CE	Capillary Electrophoresis
CEC	Capillary Electrochromatography
CSP	Chiral Stationary Phase
CS	Chiral Selector
CZE	Capillary Zone Electrophoresis
DEA	(United States) Drug Enforcement Administration
DAD	Diode Array Detection
ELISA	Enzyme-linked immunosorbent assay
EOF	Electroosmotic flow
ESI	Electrospray Ionization
EPA	(United States) Environmental Protection Agency

FID	Flame Ionization Detection
XIC	Extracted Ion Chromatogram
GC	Gas Chromatography
HPCE	High Performance Capillary Electrophoresis
HPLC	High Performance Liquid Chromatography
IS	Internal Standard
ID	Internal Diameter
LLE	Liquid-liquid Extraction
LOD	Limit of Detection
LOQ	Limit of Quantification
MC	Microcystin
MEKC	Micellar Electrokinetic Chromatography
MS	Mass Spectrometry
MS/MS	Tandem Mass Spectrometry
MSD	Mass selective detector
NPS	New Psychoactive Substance
PF	Partial Filling
RSD	Relative Standard Deviation
SDS	Sodium Dodecyl Sulfate
SPE	Solid Phase Extraction
SPME	Solid Phase Microextraction
μ TAS	Micro Total Analysis System

TLC	Thin Layer Chromatography
TIC	Total Ion Chromatogram
TOF	Time-of-flight Mass Spectrometer
UV	Ultraviolet absorption
U(H)PLC	Ultra (High) Performance Liquid Chromatography
UNODC	United Nations Office on Drugs and Crime
WHO	World Health Organization

CHAPTER 1 GENERAL INTRODUCTION

"The journey of a thousand miles begins with a single step."

Lao Tzu, Chinese philosopher, 604 BC–531 BC.

1.1 Historical Background

The history of capillary electrophoresis can be traced back to the 19th century, when Lodge described “hydrogen ion movements in a tube of phenolphthalein jelly” [1, 2] in his thesis in 1886. Later, Smirnow [3], Hardy [4, 5], and Field [6] continued the development of electrophoresis systems. During this time, separations were performed in U shaped glass tubes with electrodes attached to each of the tubes’ arms [4, 5]. In 1937, Swedish scientist Tiselius [7] successfully applied electrophoretic techniques for the separation of colloidal mixtures. As a result of his pioneering work, Tiselius was awarded the Nobel Prize in Chemistry in 1948, "for his research on electrophoresis and adsorption analysis, especially for his discoveries concerning the complex nature of the serum proteins" [8]. Professor Tiselius continued his explorations in the field of electrophoresis and a number of more inspiring results were published, including separation of virus particles in a 3 mm I.D. capillary [9-13]. In 1967, Hjerten [14] demonstrated the separation of proteins using a 3 mm I.D. capillary, which was the earliest example of the use of capillaries for electrophoretic separations with high electric fields. Afterwards in 1974, Virtanen discussed several advantages of using smaller diameter columns in electrophoretic separations. However, the studies conducted in earlier years were not able

to demonstrate the high efficiencies which the modern CE systems have because of their inability to produce stable capillary columns.

The commonly accepted modern CE system was introduced by James W. Jorgenson, who was a professor at University of North Carolina, Chapel Hill, with his graduate student Krynyn Lukacs. Because of their pioneering work in the 1980s [15-18], the CE system was widely used in academia, and resulted in CE industrial commercial availability in the late 1980s. For example, in their paper titled *capillary zone electrophoresis* published in *Science* magazine in 1983 [16], fundamental concepts of modern capillary electrophoresis such as zone broadening as well as theoretical ideas on CE separation mechanisms were proposed and presented. In the paper, they applied voltages as high as 30 kV and adapted online UV detection for the separation of ionic species.

Meanwhile, micellar electrokinetic chromatography (MEKC), another milestone of CE development, was introduced by Professor Terabe in 1984 [19]. This invention presented a method for using electrophoresis to separate both charged and neutral species and was another vital step in CE history. After that, several types of CE separation modes were invented and introduced [20-24].

Today, capillary electrophoresis is gaining great popularity as a powerful analytical tool for various applications. Figure 1.1 illustrates the number of scientific articles published over past three decades on the topic of “Capillary Electrophoresis” using capillary electrophoresis as the key word in conducting a search using the Scifinder Database.

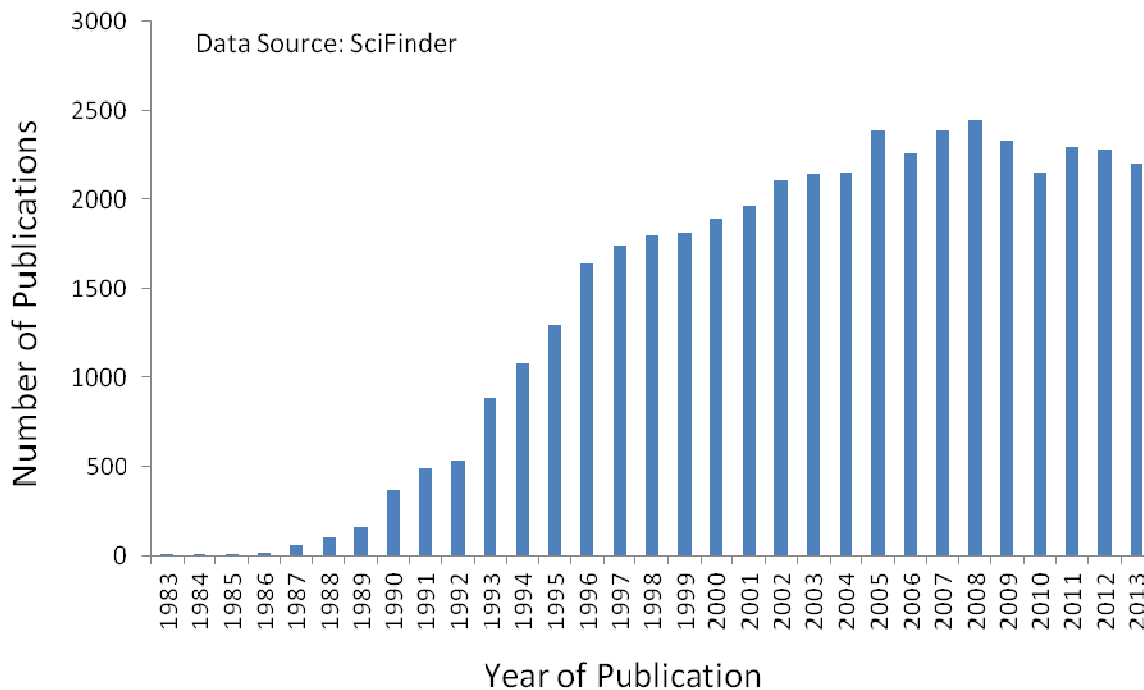

Figure 1.1 Literature published between 1983 and 2013 on the topic of Capillary Electrophoresis using capillary electrophoresis as the key work to conduct the search.

Data source: Scifinder database.

1.2 Principles of Separation in Capillary Electrophoresis

Capillary electrophoresis is a useful technique for the analysis of a wide variety of compounds, including chiral compounds, pharmaceutical molecules, peptides, and proteins [2, 25]. In particular, capillary electrophoresis has been successfully applied to the determination of drugs in toxicological samples [26]. The usage of CE in forensic analysis mainly results from advantages such as minimal sample requirements, rapid analyses, and high efficiencies.

Capillary electrophoresis separation is determined by two factors: electroosmotic flow (EOF) and electrophoretic mobility [2]. Electrophoretic mobility is the motion of liquid induced by an applied potential across a capillary column. Electroosmotic flow originates from the negative charges on the inner wall of the capillary tube, which result in the formation of an electrical double layer. This is known as the zeta potential, which is expressed by ζ , and defined by the Helmholtz equation [27].

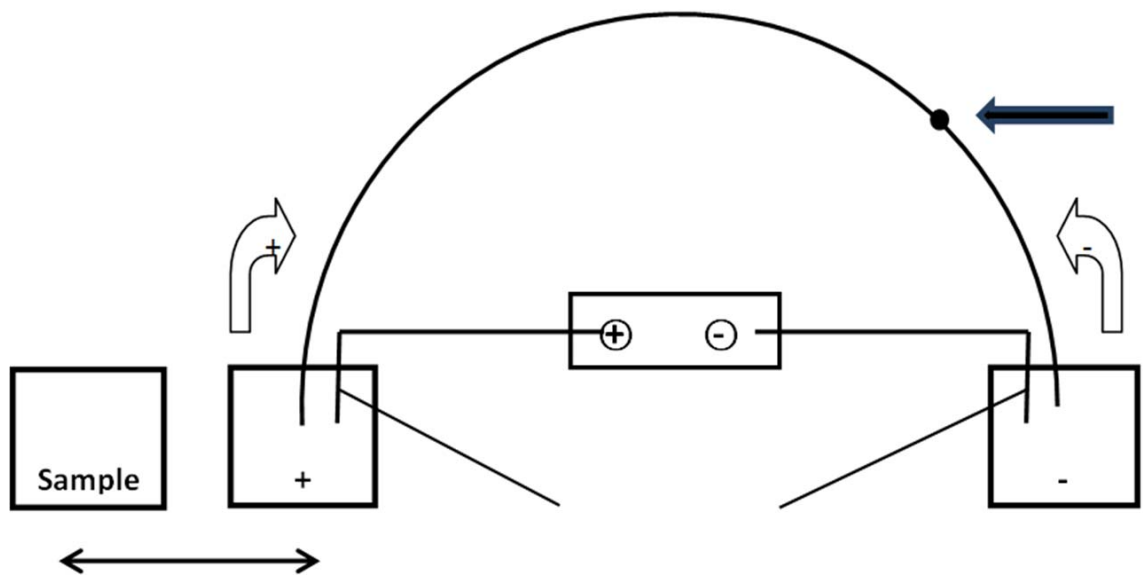

Figure 1.2 Schematic diagram of the capillary electrophoresis system. The high voltage up to 30 kV is applied at the ends of the capillary. With the force combination of electrophoretic mobility and electroosmotic flow, the samples and background electrolytes are carried through the capillary from the inlet to the outlet. A short portion of the capillary is created as the detection window in order to obtain electrophoretic spectra from UV or fluorescence detectors.

Equation 1.1 Helmholtz equation

$$\zeta = \frac{4\pi\eta \mu_{eo}}{\varepsilon}$$

where η is the viscosity, ε is the dielectric constant of the buffer, and μ_{eo} is the coefficient for electroosmotic flow. Equation 1.1 can be used to categorize the effects of various parameters on the EOF as under the influence of an applied electric field, the cations in the diffuse layer move towards the cathode, leading the solvent molecules to move in the same direction.

The linear velocity, expressed by v , of the electroosmotic flow is defined by the following equation.

Equation 1.2 Calculation of linear velocity v

$$v = \frac{\varepsilon}{4\pi\eta} E \zeta$$

And the number of the theoretical plates is expressed as Equation 1.3, where E is the potential of the electric field.

Equation 1.3 Calculation of theoretical plates (N)

$$N = \frac{(\mu_{eo} + \mu_{ep})V}{2D}$$

Where μ_{ep} is the electrophoretic mobility and D is the diffusion coefficient of the solute. Separations in CE occurs based on differences among electrophoretic mobilities of solvated ions as shown in Figure 1. High efficiencies occur in these separations because

the system flow is electro-driven rather than pressure-driven as in an HPLC system. Diffusion is minimized in the small 50 μm flow channel.

Figure 1.3 illustrates the separation mechanism of capillary electrophoresis and electroosmotic flow forms in a capillary. The wall of the capillary attracts cations in the electrolyte, and an electrical double layer is created. Once voltage is applied to the capillary, the net motion of electrolytes towards the cathode (EOF) occurs.

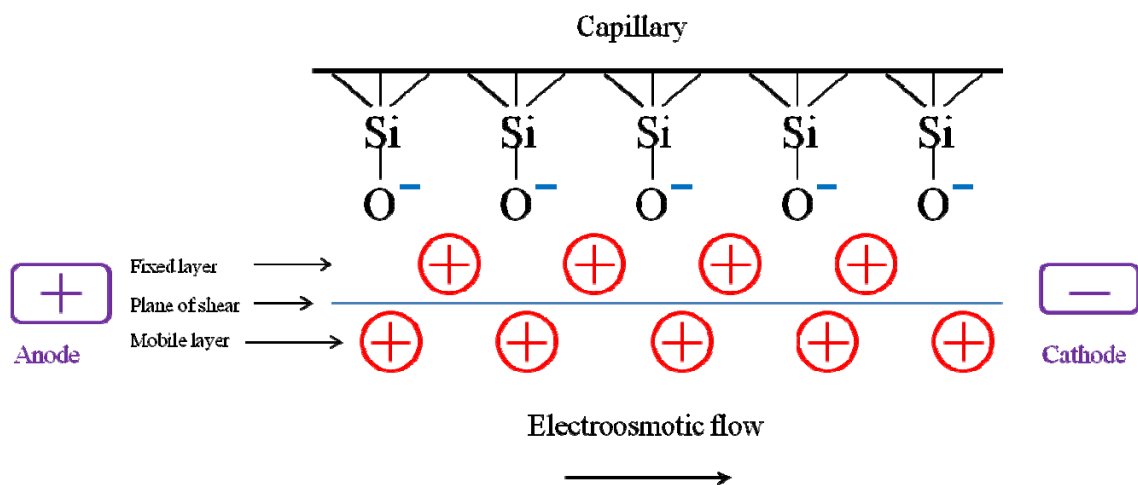

Figure 1.3 Formation of the electroosmotic flow from the double layer inside the capillary. Adapted from Ref. [28].

Equation 1.4 Separation mechanism of the capillary electrophoresis system

$$\mu = \mu_{eo} \pm \mu_{ep}$$

As stated above, the two different forces, electroosmotic flow μ_{eo} , and electrophoretic mobility μ_{ep} , play roles in the separation of the capillary electrophoresis

system. pH values have an important impact on the flow directions of the two forces, which is demonstrated as Figure 1.4.

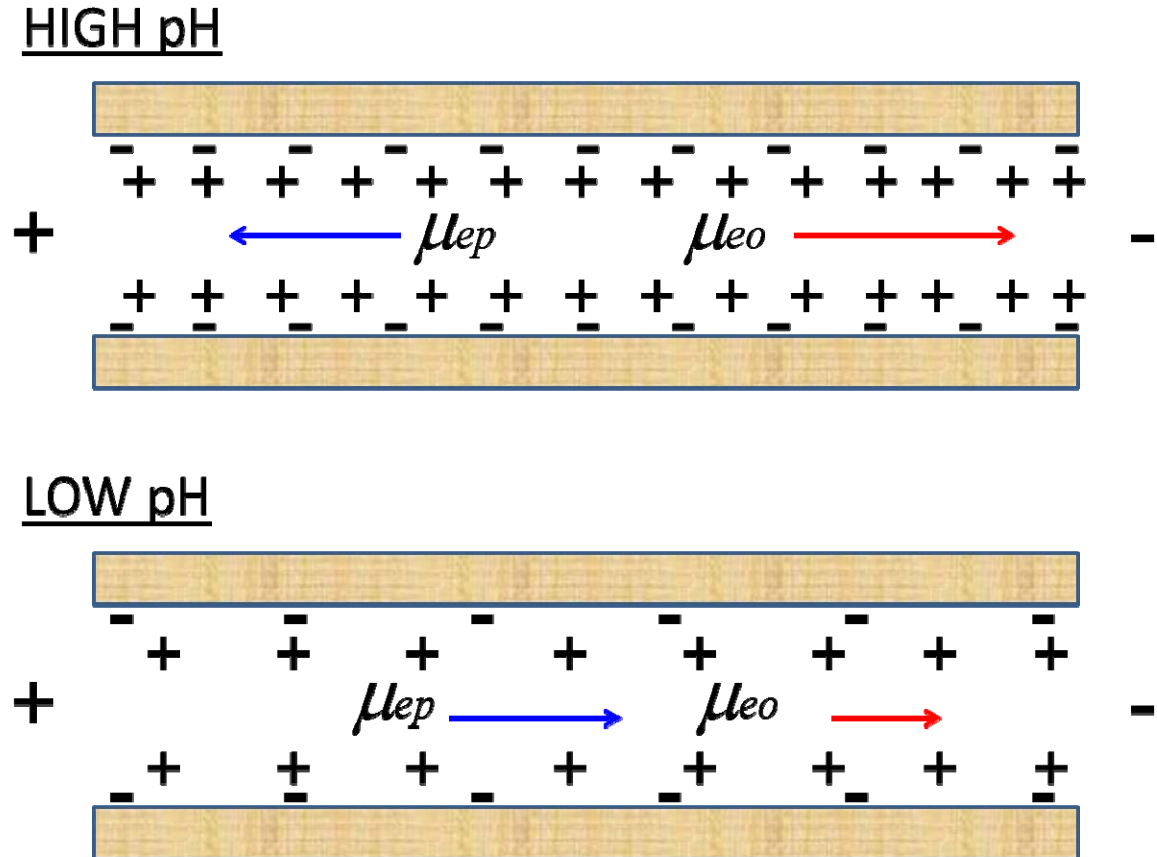

Figure 1.4 Mechanism of separations in capillary electrophoresis systems. The combination of electrophoretic mobility μ_{ep} and electroosmotic flow μ_{eo} determines the flow velocity of the eluents in the capillary. Generally, at high pH conditions, silanol groups on the inside wall of the capillary are fully ionized, generating a strong zeta potential and dense electrical double layer. The overall separation is based on the two forces.

In Figure 1.5, flow profiles in CE and HPLC are presented. As a result of its contribution to peak broadening, the pressure driven flow profile inherently limits the efficiency of HPLC. In CE, the EOF results in a flat flow profile towards the counter electrode with charged compounds migrating at various rates within this vector.

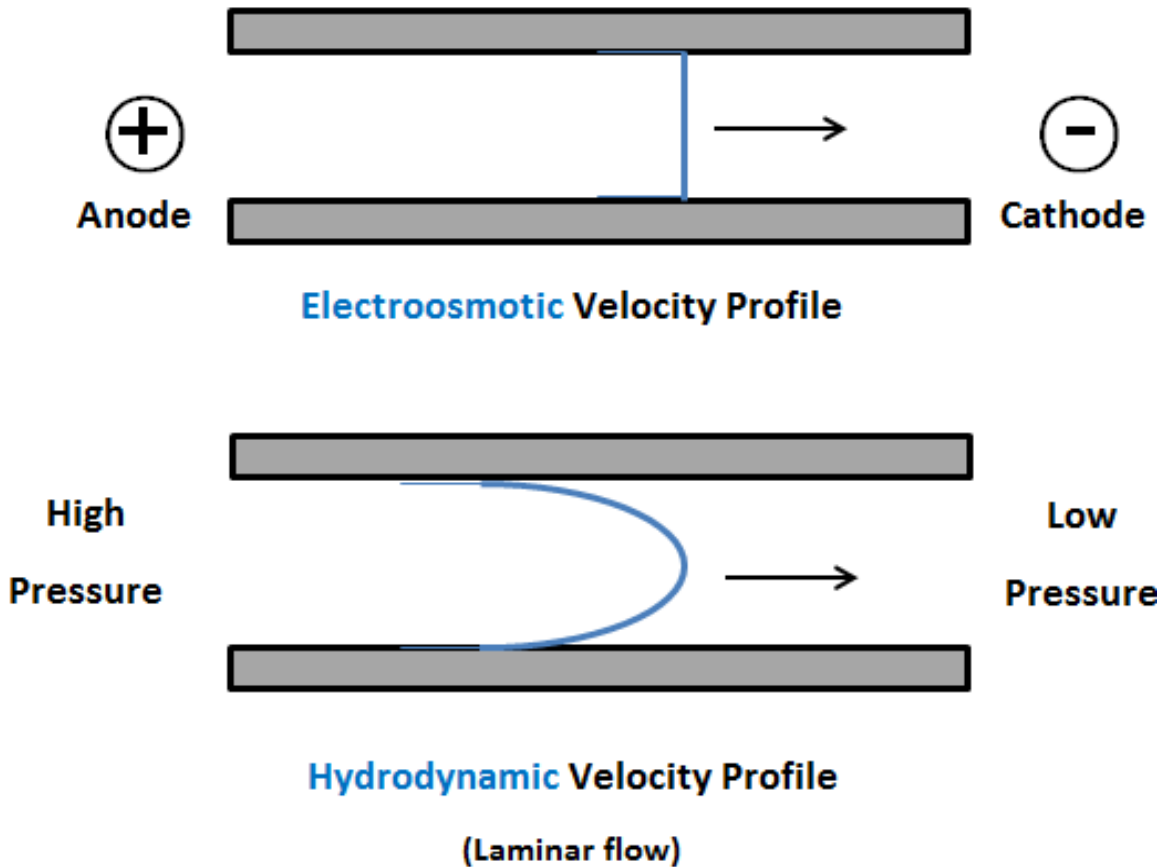

Figure 1.5 A comparison between electroosmotic flow and laminar flow. Laminar flow results in increased diffusion and band broadening and is a characteristic of HPLC separations while the flat flow profile of the EOF improves separation efficiency in CE. Adapted from Ref. [2].

Figure 1.6 displays CE sample stacking and sample injection. Samples are first injected by either electrokinetic mode (voltage) or pressure. Then high voltage up to 30 kV is applied towards the samples. Samples are moved to the outlet based on different forces.

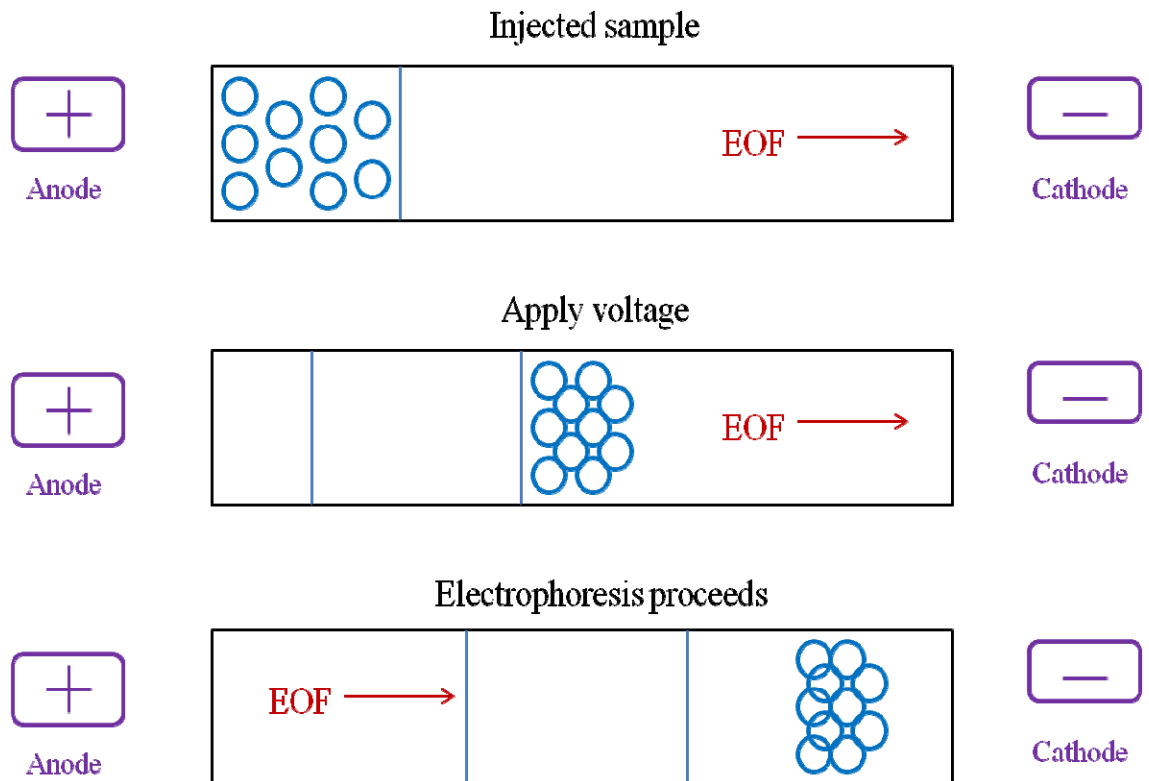

Figure 1.6 CE sample stacking and sample injection. Top: the analyte is injected. Middle: high voltage filed (up to 30 kV) is applied and since the electric potential difference exists, the samples are pushed towards the cathode end. Bottom: the sample ions are stacked and migrating though the capillary as a zone that is narrower than the sample injected. Adapted from Ref. [2] and [29].

1.3 Significance of the Work

In this dissertation, different capillary electrophoresis methods are utilized to examine effects in the separation and detection of drugs and toxins in forensic, pharmaceutical, and environmental applications.

The detection of compounds involved in illicit and prescription drug abuse

The use of illicit drugs and the concomitant large number of problematic drug users is a serious problem in work health [30]. According to the World Drug Report 2013 released by the United Nations Office on Drugs and Crime (UNODC), “between 167 and 315 million people between the age of 15–64 were estimated to have used an illicit substance” [30] in the year of 2010. This corresponds to between 3.6% and 6.9% of the adult population in the world [30]. Figure 1.7 demonstrates that since 2008 the estimated total number of people who have used an illicit drug has increased by 18%. This issue makes it vital for law enforcement officers, policy makers, and researchers to find corresponding solutions to fight against synthetic and designer drugs of abuse.

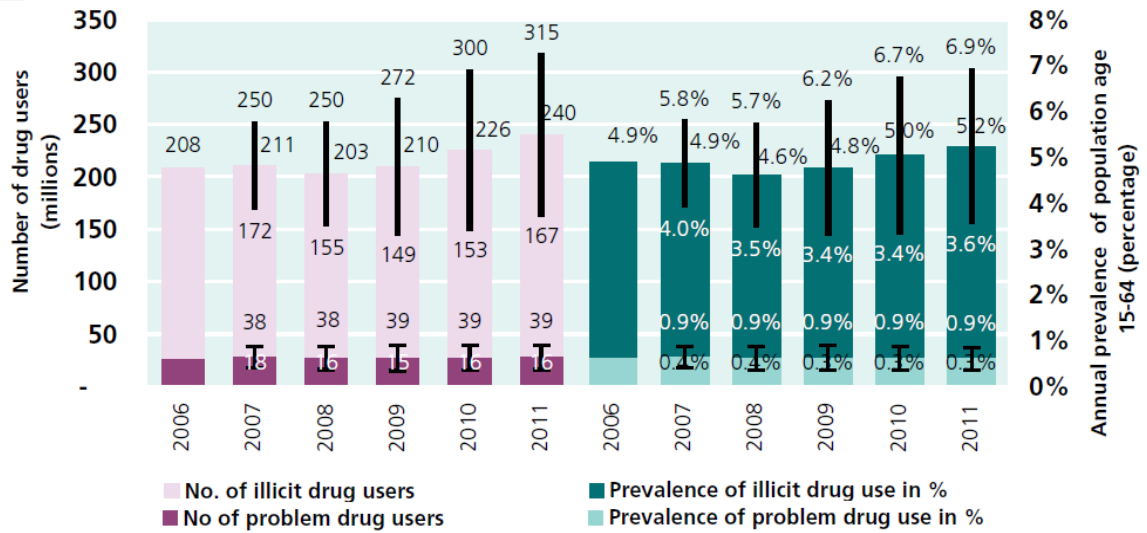

Figure 1.7 Trends in drug use from 2006 to 2011. Date source: the World Drug Report 2013, UNODC. [30]

Environmental issues

The Annual Report 2013 from the United Nations Environment Programme (UNEP) [31], and the Annual Report 2012 from Greenpeace [32], summarized various issues in the 21st century that human beings are facing, such as global warming and greenhouse effect, CO₂ emission, food safety and food security, air pollution, and drinking water shortage. Among them, drinking water safety is one of the most important aspect for human safety. A threat to clean drinking water includes cyanobacteria, which are widely distributed throughout the world, which reflects their genotypic and phenotypic variation [33]. Cyanobacteria are common in diverse types of every terrestrial habitat, including oceans, lakes, fresh water, deserts, and even in the extreme environments of Antarctica and thermal springs [34-35]. Thus, it is important to not only detect but also quantify the amount of cyanobacteria existing in drinking water

CE to the rescue

Numerous scientific publications have reported various analytical methods for analysis of synthetic and designer drugs of abuse, overdosed prescriptions, and environmental toxins such as cyanobacteria. Some application examples include HPLC and LC-MS (including LC-MS/MS) [34-41], GC and GC-MS [42-47], and other techniques [48-54] such as SFC, TPLC, and ELISA. However, capillary electrophoresis has some advantages over these approaches mentioned above, which has made CE a powerful tool for fulfilling the goal of projects in this dissertation. To summarize, capillary electrophoresis i) requires less sample injection amount; ii) has high efficiency, high selectivity, and low operation cost; iii) exhibits the ability to analyze non-volatile and highly polar compounds, and iv) demonstrates relatively easy column modification to achieve chiral separation ability.

This dissertation is focused on development of novel CE techniques for forensic, pharmaceutical, and environmental applications. A number of approaches were examined for different applications and are presented in each following chapters.

CHAPTER 2 MONOLITHIC CAPILLARY ELECTROCHROMATOGRAPHY FOR THE TRICYCLIC ANTIDEPRESSANTS

2.1 Introduction

2.1.1 Introduction of the project

Worldwide issues with poisoning and death from clandestine drug manufacturing demonstrate the need for effective methods that can not only detect low levels of drugs but also accurately confirm their molecular information. In this way law enforcement can better track users and victims of these products. In addition, the field of toxicology has become increasingly vital as researchers and practitioners recognize the importance of defining the precise role different drug combinations play in human behavior [33]. As a result, a large number of studies have been conducted to develop better ways to detect the presence of dangerous drugs [34-37]. The goal of the research described in this chapter is to develop novel methods for the detection of drugs using capillary electrochromatography (CEC).

Trace detection of pharmaceutical compounds typically employs several analytical techniques, including gas chromatography-mass spectrometry (GC-MS) and liquid chromatography-mass spectrometry (LC-MS). For the separation of drugs with very similar structural and physical properties, these techniques may require specialized stationary phases or additional derivatization for some samples in order to increase method selectivity. An alternative to above techniques is to utilize capillary

electrophoresis (CE). Because of its high resolution and excellent peak capacity, capillary electrophoresis can be a powerful alternative to traditional separation methods for ionic analytes as well as neutral drugs. To permit the separation of neutral drugs, compounds may be added to the buffer to produce guest/host and micellar/solute interactions with the analytes. Using compounds such as cyclodextrins in the buffer, even chiral compounds can be separated [2]. However, while capillary electrophoresis coupled with UV, electrochemical or fluorescence detection can be used to presumptively determine the presence of a particular compound, mass spectrometry connected to chromatography is necessary for absolute identity of any drugs present in sample matrix [55]. For toxicological analysis a number of useful procedures have been developed for the detection and screening of compounds by capillary electrophoresis-mass spectrometry (CE-MS) including low sample consumption and the potential for highly efficient chiral analysis. However, current applications involving neutral or chiral drug detection by CE procedures have been problematic [2, 25]. Since these procedures perform separations utilizing non-volatile detergents or cyclodextrin-based pseudo-stationary phases, these methods generally are incompatible with electrospray ionization methods that require volatility. One potential solution for this issue is to operate the CE-MS system in a partial filling mode to avoid spraying the reagent into the mass spectrometer. However, the partial filling method is not often viable because of problems controlling the timing of the capillary fill step and the potential instability of buffer gradient step that results from the process.

Capillary electrochromatography (CEC) is an alternative method for electrophoretic separation that can be employed in the application of drug analysis. This procedure is a novel technique which permits the detection of neutral compounds by combining the high efficiency of CE with the outstanding selectivity of HPLC. In CEC, the capillary column is packed with an HPLC type stationary phase, which allows the separation to occur via sample partitioning between the packed stationary phase and an electrodriven mobile phase. An efficient way to produce the stationary phase is through *in-situ* polymerization into a so called polymer monolith. When coupled with mass spectrometry, the procedure has been shown to provide efficient and sensitive detection of drugs and their metabolites in biological fluids.

2.1.2 Background and significance of capillary electrophoresis and capillary electrochromatography

Capillary electrochromatography was first introduced by Pretorius [56] and a wide variety of applications have been developed for the technique [57]. In CEC a high voltage is applied across the capillary, to generate EOF and move the mobile phase along with analytes through the column. Separations for CEC are a consequence of both differential partitioning and electrophoretic migration in mobile phases, which typically include a mixed aqueous/organic buffer [58]. Since CEC is a hybrid of CE and HPLC, high pressure is introduced to the system in order to assist with the electrophoretic mobility as well as reducing the formation of bubbles when preparing monolithic capillary columns.

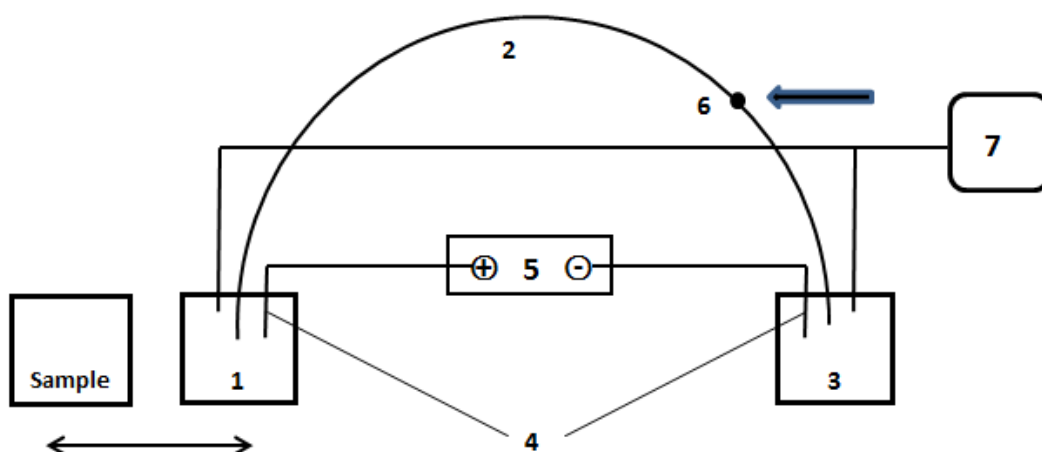

Figure 2.1 Schematic diagram of the CEC system. 1, inlet buffer vials; 2, capillary; 3, outlet buffer vials; 4, electrodes; 5, power supply; 6, point of detection; 7, external pressure 2-12 bar. The power supply (5) provides voltages up to 30 kV to the two buffer vials at the distal ends of capillary (1, 3). The applied voltage creates an electroosmotic flow (EOF) within the capillary (3) moving the analytes down the column where they interact with the stationary phase. A detection window (6) is placed near the end of the capillary which is typically UV, fluorescence, or mass spectrometry. Adapted from Ref. [2].

In CEC, the stationary phase has two major roles: to provide charged sites to permit the desired EOF for mass transport across the column, and to offer interactive sites for chromatographic retention. A convenient way to generate a CEC stationary phase with proper anionic character for generating EOF involves the production of monolithic stationary phases. A monolithic column is defined as “A continuous unitary porous structure prepared by *in situ* polymerization or consolidation inside the column tubing and, if necessary, the surface is functionalized to convert it into a sorbent with the desired

chromatographic binding properties” [59]. Two approaches can be used for making monolithic stationary phases: sol-gels and organic polymers. The polymeric method is often used because of its simplicity. In addition, the polymeric method is easy to chemically modify to induce selectivity changes [25, 60]. The procedure consists of four main steps: first using a promoter solution for pretreatment of the capillary walls to increase sorption sites; the polymerization mixture is then used for flushing the capillary. Under UV radiation exposure or heat, the mixture is initiated by *in situ* polymerization. Lastly, unreacted components are removed and a detector window is created by exposing a section to UV light [27, 58]. The polymerization mixture is made of monomers, a chemical initiator, and the porogen. The charged monomers assist in generating electroosmotic flow, while the retentive monomers establish partitioning sites. Separation selectivity can be enhanced by altering the hydrophobicity of the capillary’s stationary phase [60]. The monolithic polymerization process may include altering the functional groups on the monomer or altering the carbon chain length [61]. Formation of the polymer chains is enhanced by the cross-linker, and the free radical polymerization process is started by the initiator, resulting in the formation of the monolithic column. The porogens play an important role as well because they assist in the formation of a large network of pores in the polymeric monolith through which the mobile phase can traverse [60].

Blas *et al.* [58] described the separation and detection of benzodiazepines in urine samples using monolithic CEC-TOF-MS. Enhanced sensitivity was achieved because of

two factors: the usage of the TOF-MS system and preconcentration at the tip of the capillary containing the monolithic materials.

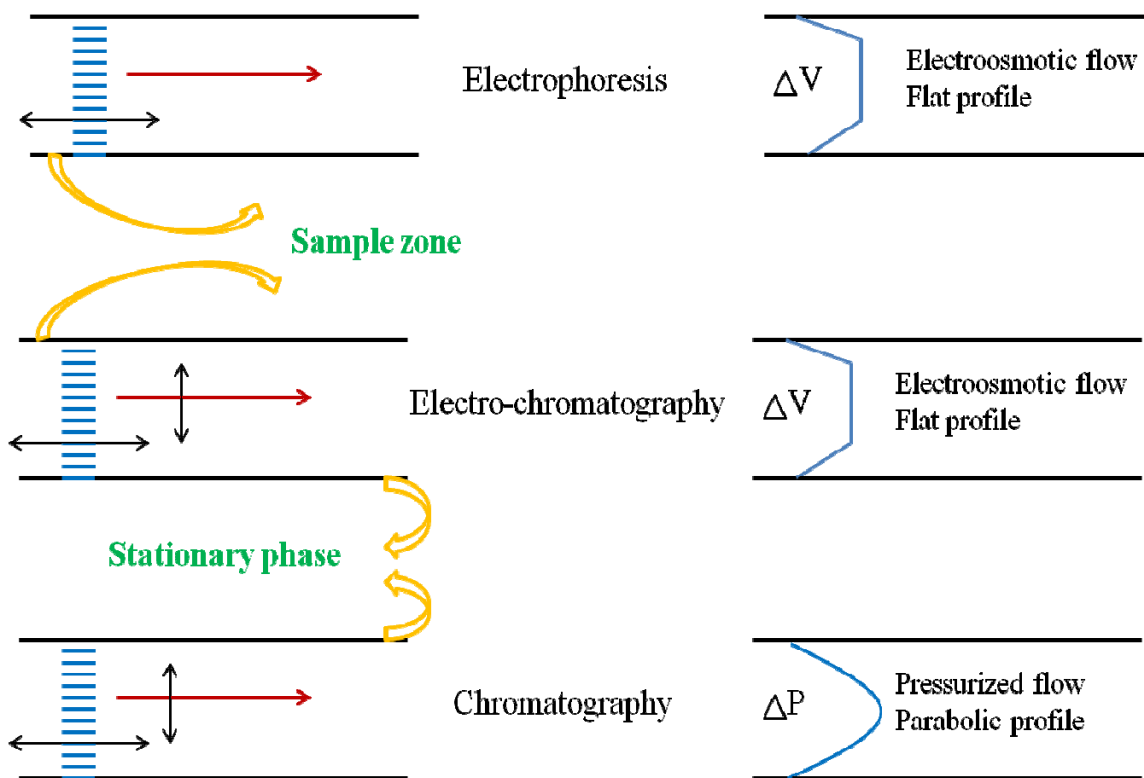

Figure 2.2 Comparison of electrophoresis, electrochromatography and chromatography. Different flow profiles are exhibited for electrophoresis, electrochromatography, and chromatography. Adapted from Ref. [62].

Separation selectivity can be enhanced by altering the monomers and side groups [62-63]. For example, hydrophobicity can be altered through increases in the length of the carbon side group from hexyl to octadecyl acrylate. Charge density and pore size can also affect separation through changes in sulfonate concentration and through increased addition of cross linkers [57-59].

Antidepressants (ATD), as the names indicate, are substances with a wide range of therapeutic uses for treatment of depressive disorder, and other conditions such as anxiety and dysmenorrhoea. The World Health Organization (WHO) reported that depression is the world's third-leading cause of death loss [63]. Because of their side effects and possible harmful potential, strict limitation is placed on the usage of antidepressants. Among the wide variety of antidepressants, the most significant classes are the selective serotonin reuptake inhibitors (SSRIs), serotonin–norepinephrine reuptake inhibitors (SNRIs), tricyclic antidepressants (TCAs), and monoamine oxidase inhibitors (MAOIs) [64, 65]. In this project, I focused mainly on TCAs (Figure 2.3).

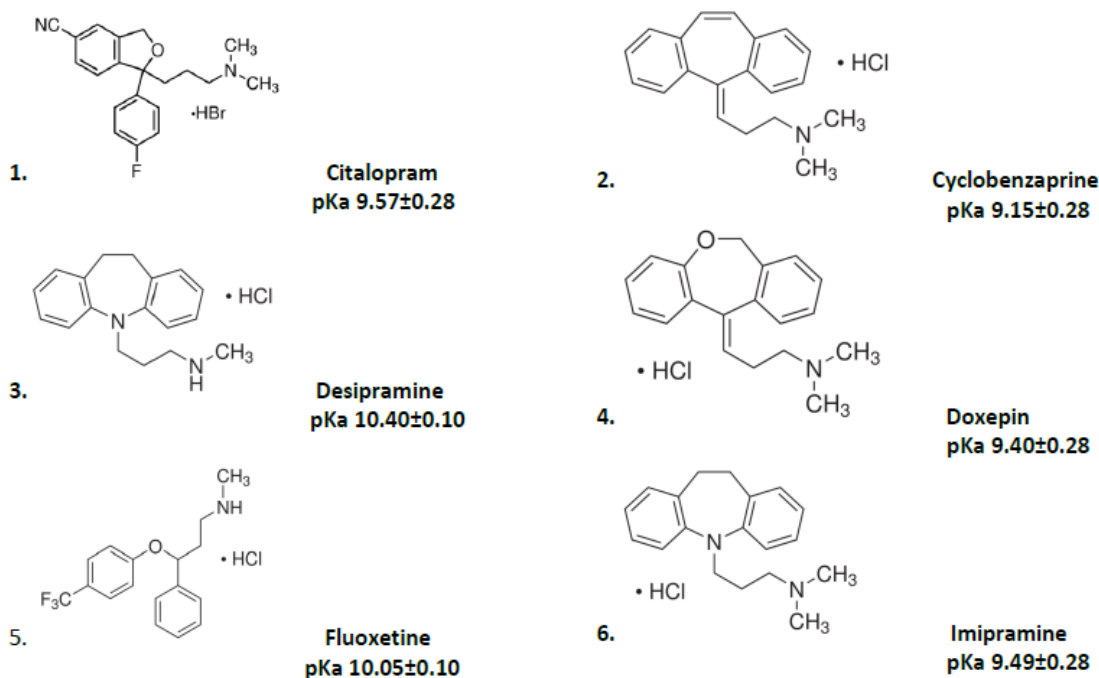

Figure 2.3 Structures of analytes used in Chapter 2

A number of different analytical techniques have been used in the trace detection of antidepressant compounds. Gas chromatography (GC) and gas chromatography – mass

spectrometry (GC-MS) [66-69] have been used to analyze ATD compounds. However, chemical derivatization is required to increase volatility of many analytes to permit compatibility with GC methods. High performance liquid chromatography (HPLC) and liquid chromatography – mass spectrometry (LC-MS) [70-74] have often been used as an alternative to GC and GC-MS for these compounds. However, most published work was focusing on screen and determination rather than separation [73-75]. A useful alternative is capillary electrophoresis. A number of capillary electrophoresis (CE) and CE combined with MS methods have also been explored [26, 75-77].

Capillary electrochromatography (CEC) as an alternative method can be employed in the application of drug analysis. Electrochromatography was first introduced by Pretorius [56]. In CEC a high voltage is applied across the capillary, to generate EOF and move the mobile phase through the column. Several applications of CEC monolith capillary columns have been reported and reviewed [61, 78-83]. However, to the author's knowledge, there are no published reports on the use of acrylate-based monolithic CEC for ATDs detection.

2.2 Experimental

2.2.1 Chemicals and materials

Fused-silica capillaries with an inner diameter of 100 μm and a UV-transparent coating were purchased from Polymicro Technologies (Phoenix, AZ, USA). Hexyl acrylate (HA), 2-acrylamido-2-methyl-1-propanesulfonic acid (AMPS), 2,2'-azobisisobutyronitrile (AIBN), and sodium phosphate dibasic heptahydrate were obtained

from Acros Organics (Morris Plains, NJ, USA). One, three-butanediol diacrylate (BDDA), trimethoxysilylpropyl acrylate (TMSA), ammonium acetate, ammonium dihydrogen phosphate, ammonium formate, and sodium phosphate monobasic monohydrate were obtained from Sigma Aldrich (St. Louis, MO, USA). Acetone, acetonitrile, and ethanol from were purchased from Fisher Scientific (Pittsburgh, PA, USA). Distilled water was deionized by a Milli-Q water purification system (Millipore, Bedford, MA, USA). Antidepressants standards were purchased from Sigma Aldrich (St. Louis, MO, USA).

Table 2.1 Chemical components of monolithic mixture

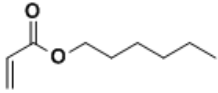
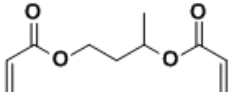
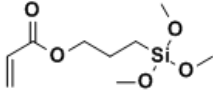
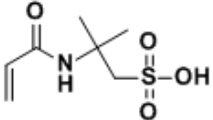
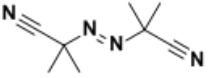
Chemical Name	Chemical Structure	Function
Hexyl Acrylate (HA)		Monomer
1,3-butanediol diacrylate (BDDA)		Cross-linker
trimethoxysilylpropyl acrylate		Adhesion Promoter
2-acrylamido-2-methyl-1-propanesulfonicacid (AMPS)		Support Electroosmotic Flow
2,2'-azobisisobutyronitrile (AIBN)		Free Radical Initiator for Polymerization

2.2.2 Instrumentation

All experiments were carried out using a fully automated capillary electrophoresis system (G1600, Agilent Technologies, CA, USA) with the column temperature maintained at 25°C. Separations were performed in 100 µm ID uncoated fused silica capillaries with a total length of 60 cm and an effective length of 50 cm. The running voltage was 30 kV and samples were injected using the electrokinetic injection mode for 5 s at 10 kV. A built-in diode-array detector (DAD) was employed to record UV spectrum. All analytes were scanned from 190 nm to 450 nm, and 206 nm was selected to enable maximum sensitivity for analytes [53]. The separations were performed at field strengths of 150-950 V/cm.

For spiked urine sample analysis, an Agilent 3250a time-of-flight mass spectrometer (TOF-MS) was employed in addition to the CE system. An orthogonal electrospray ionization (ESI) interface was used to couple CE with TOF-MS. Reference masses obtained from Agilent (G1969-85001 API-TOF reference mass solution kit) including purine at 121.0509 m/z and HP0921 at 922.0098 m/z were added to the sheath flow liquid to calibrate the mass spectrometer. The mass range was set to 100-1000 m/z to include both reference masses. Applied Biosystems/MSD-SCIEX Analyst QS Software (Frankfurt, Germany) was employed for data analysis. All experiments were performed in positive ion mode. The TOF-MS conditions were shown in Table 2.2.

Table 2.2 ESI-TOF-MS experiment conditions for analysis of spiked urine samples

Parameter	Value
Capillary Voltage	3000 V
Nebulizer pressure	10 psi
Drying gas (N ₂)	5 L/min
Gas temperature	150 °C
Fragmentor voltage	125 V
Skimmer voltage	40 V
Octapole RF	300 V
TOF/PMT	1025 V
Mass range (<i>m/z</i>)	0-1000
Sheath flow	0.5 mL/min
Reference	121.0509, 922.0098

2.2.3 Monolithic capillary preparation

A method of making monolithic CEC columns was originally developed by Ngola *et al.* [84] and modified to prepare monolith columns. The procedure consists of four main steps: first using a promoter solution for pretreatment of the capillary walls in order to increase sorption sites; the polymerization mixture is then used for flushing the capillary [58]. Under UV radiation exposure or heat, the mixture is initiated by in situ polymerization. Lastly, unreacted components are removed and a detector window is created by exposing a section to UV light [27, 58].

The polymerization mixture is made of monomers, a chemical initiator, and the porogen. The charged monomers assist in generating electroosmotic flow, while the retentive monomers establish partitioning sites. Briefly, the monolithic mixtures consisting of 1357 μL HA, 591 μL BDDA, 0.0145 g AMPS, 0.0098 g AIBN and 4 μL TMSA were prepared. A pH 6.8 sodium phosphate buffer was made from a solution containing 3 mM sodium phosphate monobasic and 4 mM sodium phosphate dibasic with 1.0 M NaOH adjusting to desired pH value. The porogenic mixture was composed of acetonitrile, ethanol, and sodium phosphate buffer at 3:1:1 volumetric ratio. The monomer mixture was mixed with the porogen at a 1:2 volumetric ratio. Five min of sonication was needed to remove bubbles in the mixture.

Pretreatment towards the capillary was made prior to use, which includes flushing the capillary with acetone for 5 min followed by 1.0 M sodium hydroxide for 60 min and then treating the inner wall with 4 μL of trimethoxysilylpropyl acrylate in 1 mL 6 mM acetic acid for 10 min. The capillary has to be flushed with water for 30 min to remove any residual solvent residuals and dried with a flow of nitrogen gas.

The capillary was filled with the polymerization mixture by immersing the inlet of the capillary into a reservoir and pushing the polymerization solution through the capillary under gas pressure. After 30 min, both ends of the capillary were sealed. A UV detection window was created by masking a 1 cm portion of capillary by aluminum foil. The capillary was then placed into an UV box at 365 nm for the duration of 1 h at room temperature. Then 2 cm of both ends were cut and the capillary was put in the CE instrument for experiments. The monolith must be present in the entire capillary.

2.2.4 Sample preparation

Antidepressant samples were prepared as following procedures. Stock solutions were prepared in methanol at a concentration of 1 mg/mL. When not in use, the stock solution was stored in the freezer at $-18\text{ }^{\circ}\text{C}$. For experimental usage, the stock solutions were pipetted, dried down under nitrogen, and diluted to concentrations ranging from 5 ng/mL to 1 mg/mL using deionized water with 10% buffer. Fresh samples were prepared daily.

To check method capability, urine was spiked with cyclobenzaprine, desipramine and imipramine at concentrations ranging from 25 ng/mL to 1mg/mL (IRB Protocol Approval #: IRB-13-0474) to mimic forensic samples.

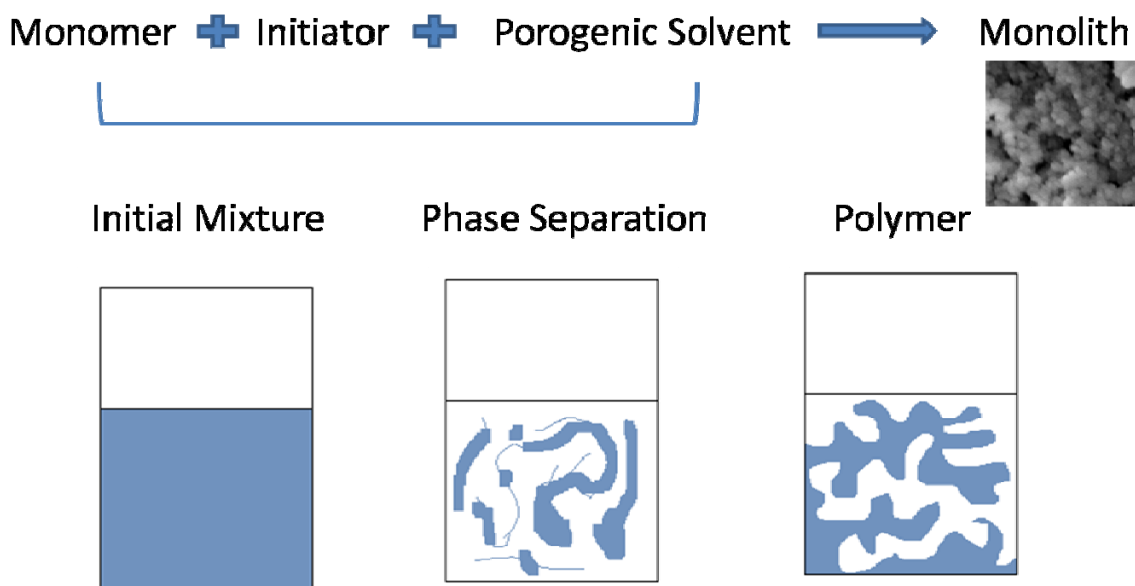

Figure 2.4 Monolithic column preparation procedure. The monolithic materials are synthesized by monomer mixtures, a chemical initiator, and porogenic solvents.

2.2.5 Liquid-liquid extraction

A liquid-liquid extraction procedure was employed [58] and adjusted as follows: 1000 μL of spiked urine was mixed with 200 μL of 100 mM ammonium acetate at pH of 12 and then extracted with 500 μL ethyl acetate. One hundred mL of 0.1 M NaOH was then added to the aqueous phase and extracted again with 500 μL ethyl acetate. The organic phases were dried down and reconstituted in deionized water with 10% phosphate buffer.

2.3 Results and Discussion

2.3.1 Monolithic columns

Several chemical reactions are involved in the monolithic polymerization procedure. The first step is the decomposition of 2,2'-azobisisobutyronitrile (AIBN).

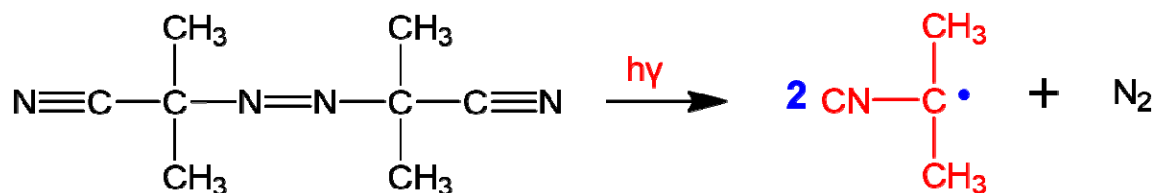

Equation 2.1 Decomposition of 2,2'-azobisisobutyronitrile (AIBN)

A 2,2'-azobisisobutyronitrile molecule has one nitrogen-nitrogen double bond and two carbon-nitrogen triple bonds. Because N=N has lower bond energy than C \equiv N, the AIBN molecule will take apart into two equal products and the N=N double bond is where the free radical reaction takes place. The product will be a t-butyl carbon group

with free radicals attached on, which provides reactions sites for the next polymerization steps.

The second step of the polymerization procedure is the monomer initiation. The monomer, hexyl acrylate, reacts with free radicals produced in the first step. The free radical attacks the carbon carbon double bond C=C in the hexyl acrylate molecule and produces a hexyl carbon chain free radical.

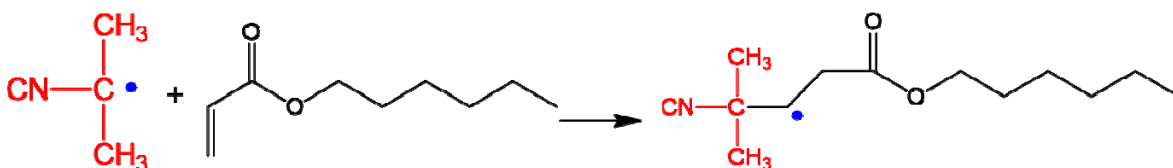

Equation 2.2 Monomer hexyl acrylate (HA) initiation

Next, the produced hexyl carbon chain free radical continues reacting with hexyl acrylate molecules, producing complex hexyl carbon chain free radicals.

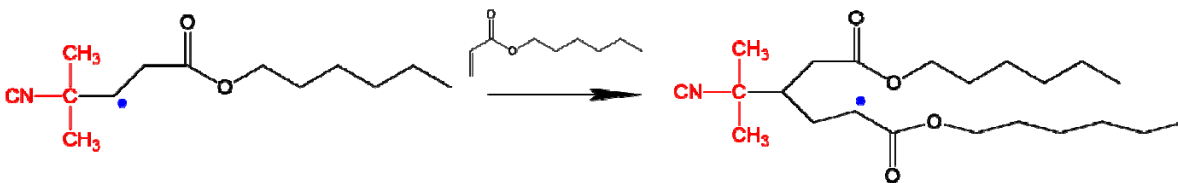

Equation 2.3 Monomer propagation

The polymerization reaction continues till it is terminated when the UV initiation source is removed. In the case of the reaction used in this project, the UV exposure time is set to 60 min.

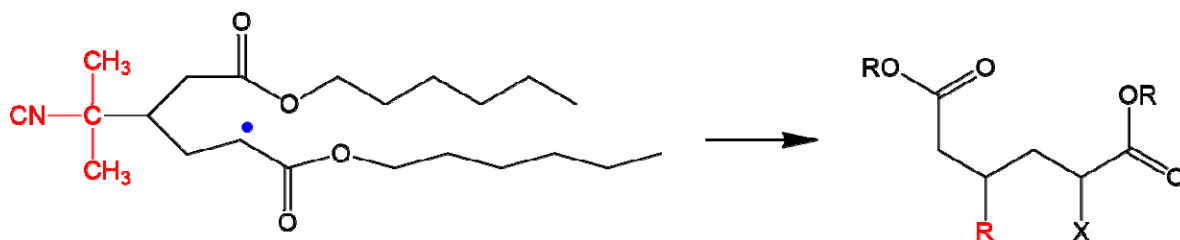

Equation 2.4 Termination of the polymerization reaction

2.3.2 Method development and CEC-UV results

The first step of the method development was to fabricate monolithic capillary columns, which provided advanced separation performance. Two methods exist for the characterization of the quality of a monolithic column. First, UV/Vis spectra of samples in the column can be obtained. Second, SEM can be utilized to image the monolithic materials inside the column. The figure below illustrates a comparison of effective and non-effective monolithic capillary columns.

Once monolithic columns were successfully fabricated, their performance was optimized and characterized. Firstly, the effect of pH was examined. The optimal wavelength was set at the 206 nm as the UV detection wavelength by examining the scan of 190 nm to 450 nm to maximize sensitivity.

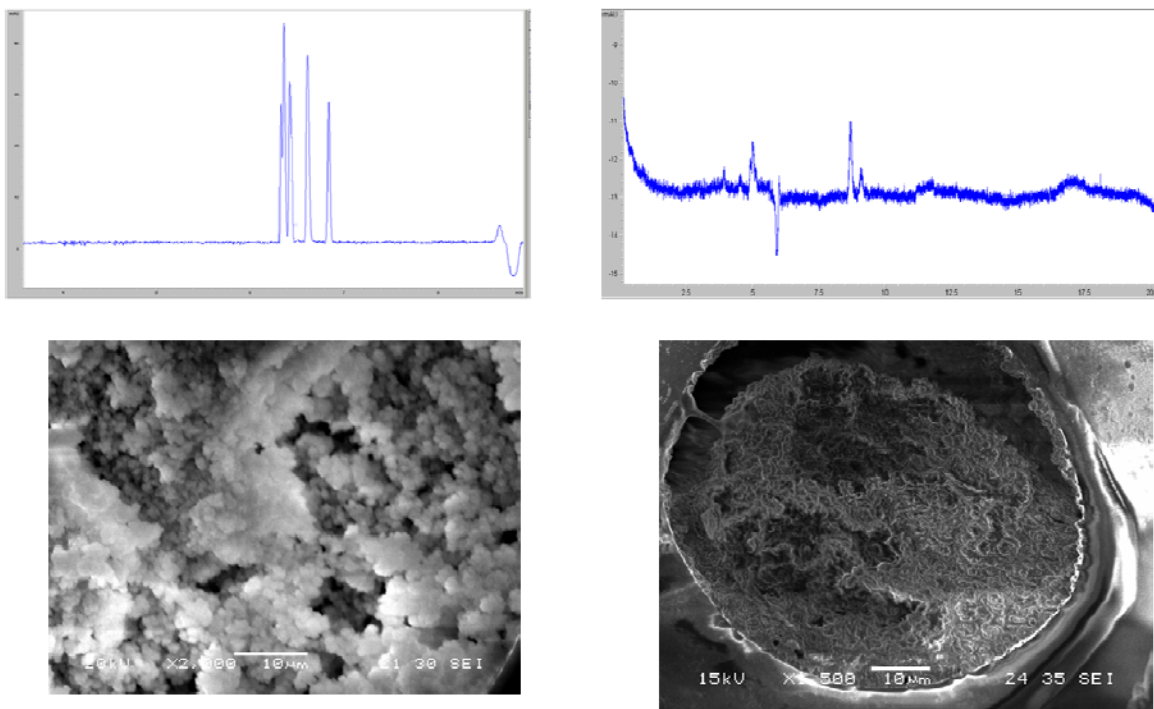

Figure 2.5 Comparison of effective (left side) and non-effective (right side) monolithic capillary columns.

Preliminary results indicated that phosphate buffer was the optimum buffer for separation [85, 86]. To begin with, running buffers at different pH's was investigated. pH's at 2.52, 3.60, 6.13, and 6.95 were examined (Figure 2.7). From these results it can be concluded that at higher pH conditions, antidepressants were better separated.

To optimize voltage and injection times, a sample containing 200 ng/mL of desipramine was injected at different voltages and injection times. A comparison between different injection conditions is listed in Table 2.3.

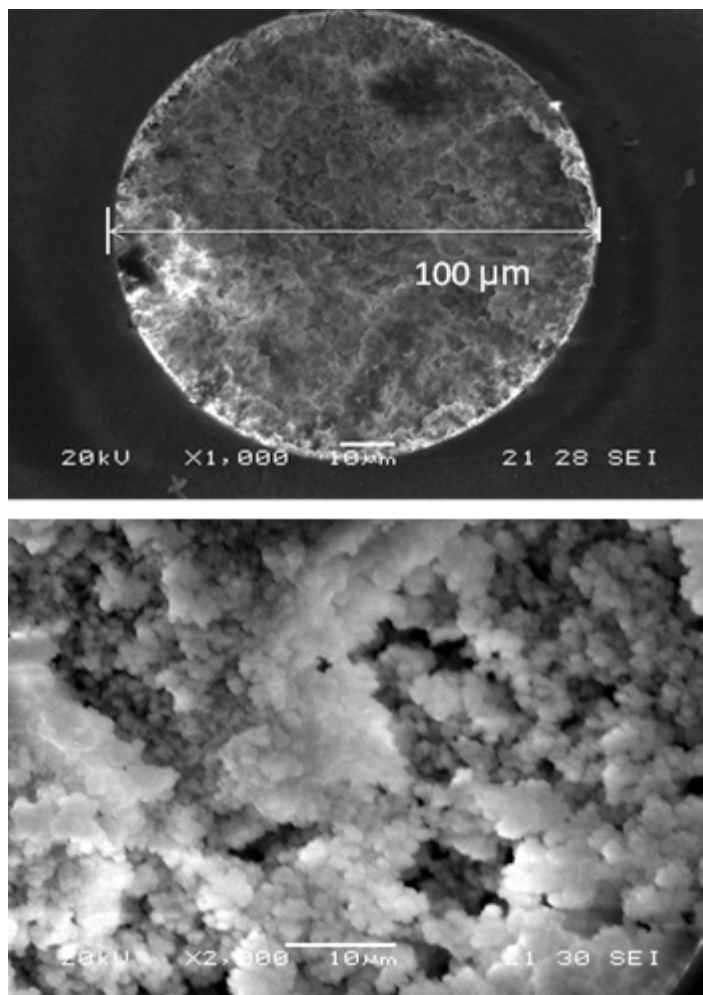

Figure 2.6 Scanning electron micrographs of hexyl acrylate monolithic column. Entire capillary (top) and enlargement (bottom). Micrographs were taken at 20 kV high electric field with x1,000 zoom (top) and x2,000 zoom (bottom), respectively. From the top figure, it can be viewed that proper polymerized materials were built inside the column and the polymeric materials taken full space inside the column. From the bottom figure, porous structure was well developed and the monolithic materials were tightly attached to the capillary wall, which indicated that the polymerization process was well finished.

Table 2.3 Effect of voltage and duration of injection on peaks. Values are given as percentage in relation to the value for 5 kV – 10 s injection.

Injection	Height	Weight	Resolution
5 kV – 5 s	60	96	96
5 kV – 10 s	100	100	100
10 kV – 10 s	195	107	93
15 kV – 8 s	232	112	95

Various combinations of injection time and voltage were tested, including 5 kV – 5 s, 5 kV – 10 s, 10 kV – 10 s, and 15 kV – 8 s. Among these parameters, 5 kV – 10 s demonstrated optimum results in terms of resolution and peak shape. All other combinations of injection are compared with 5 kV – 10s and the results are shown in Table 2.3. If longer injection time was used, more samples were injected and sample stacking would occur in the capillary; if less injection time adapted, less samples were injected and the peak intensity might be lower and not intense enough. For the injection voltage, similar principles apply. It can be concluded that 10s is a proper time span to ensure enough amount of samples injected into the monolithic columns. Also comparing 5 kV with 10 kV, 5 kV is relatively proper than the 10 kV.

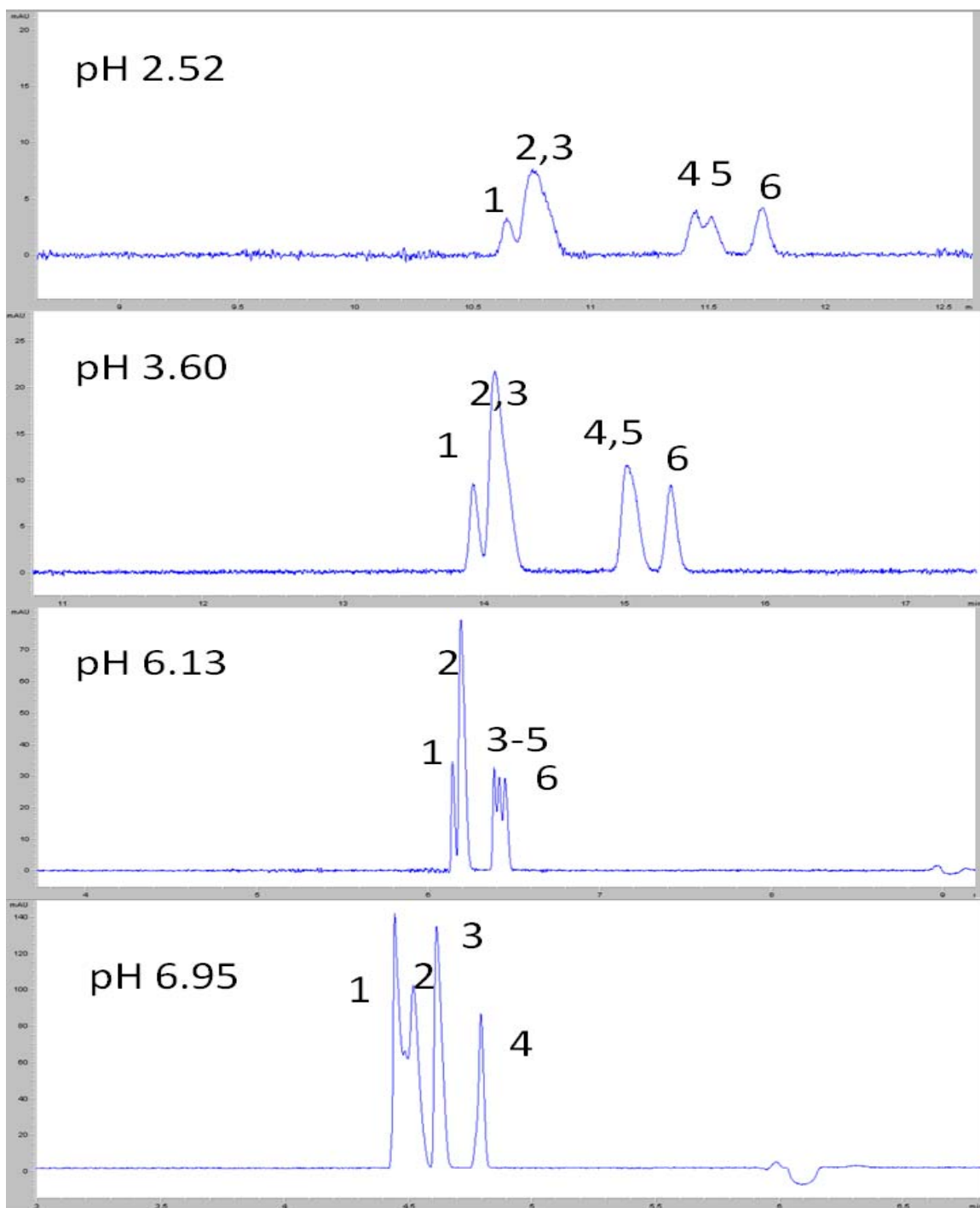

Figure 2.7 CE-UV separations using monolithic capillary columns at different pH conditions. Sample: a mixture of 6 antidepressants at 5 $\mu\text{g/mL}$. BGE: ACN:Phosphate Buffer 30:70. Peak identification: Desipramine (1); Cyclobenzaprine (2); Citalopram (3); Imipramine (4); Doxepin (5); Fluoxetine (6). Optimum separation conditions and results are shown in Figure 2.8.

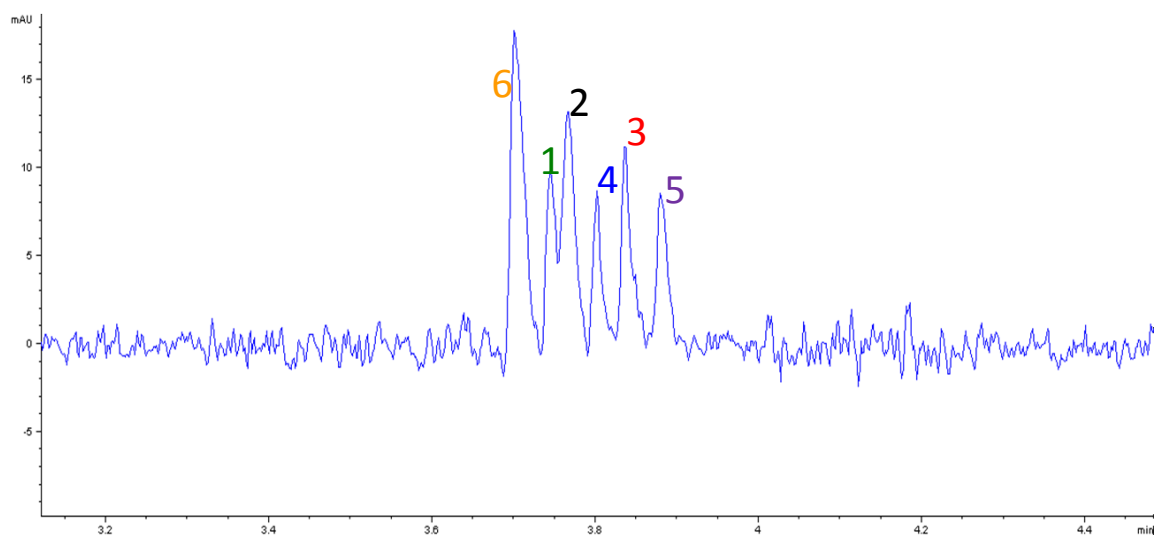

Figure 2.8 Electropherogram of a mixture of six compounds at 50 ng/mL. BGE: ACN:Phosphate Buffer 30:70. Run voltage: 30 kV. Injection: 5 s at 10 kV. Cassette temperature: 25 °C. Peak identification: Desipramine (1); Cyclobenzaprine (2); Citalopram (3); Imipramine (4); Doxepin (5); Fluoxetine (6).

Figure 2.8 demonstrates that six antidepressant compounds were separated using monolithic capillary columns and analyzed by DAD UV detection. The separation conditions are listed in the legend.

The analytical measurements of the CEC-UV experiments is presented as Table 2.4. Figures of merit for each analyte including slopes of the calibration curve, coefficient of determination (R^2), LOD and LOQ are calculated. LOD down to 11 ng/mL was obtained.

Table 2.4 Figures of merit for the CEC-UV results ($n \geq 5$)

Compound	Slope, k (peak area vs. conc.)	R^2	LOD (ng/mL)	LOQ (ng/mL)
Cyclobenzaprine	35.45	0.9816	33	100
Citalopram	57.98	0.9991	12	36
Imipramine	32.9	0.9985	11	32
Doxepin	37.6	0.9976	22	66
Desipramine	30.1	0.9830	27	80
Fluoxetine	50.7	0.9995	19	57

2.3.3 Liquid-liquid extraction and spiked urine sample

In order to determine the capability of the procedure for the analysis of biological samples, liquid-liquid extraction was explored using spiked urine samples. The urine samples were collected using IRB approved protocols from human volunteers (IRB-13-0474).

As stated earlier, 1000 μL of spiked urine was mixed with 200 μL of 100 mM ammonium acetate at the pH of 12 and then extracted with 500 μL ethyl acetate. One hundred mL of 0.1 M NaOH was then added to the aqueous phase and extracted again with 500 μL ethyl acetate. The organic phases were dried down and reconstituted in deionized water with 10% phosphate buffer.

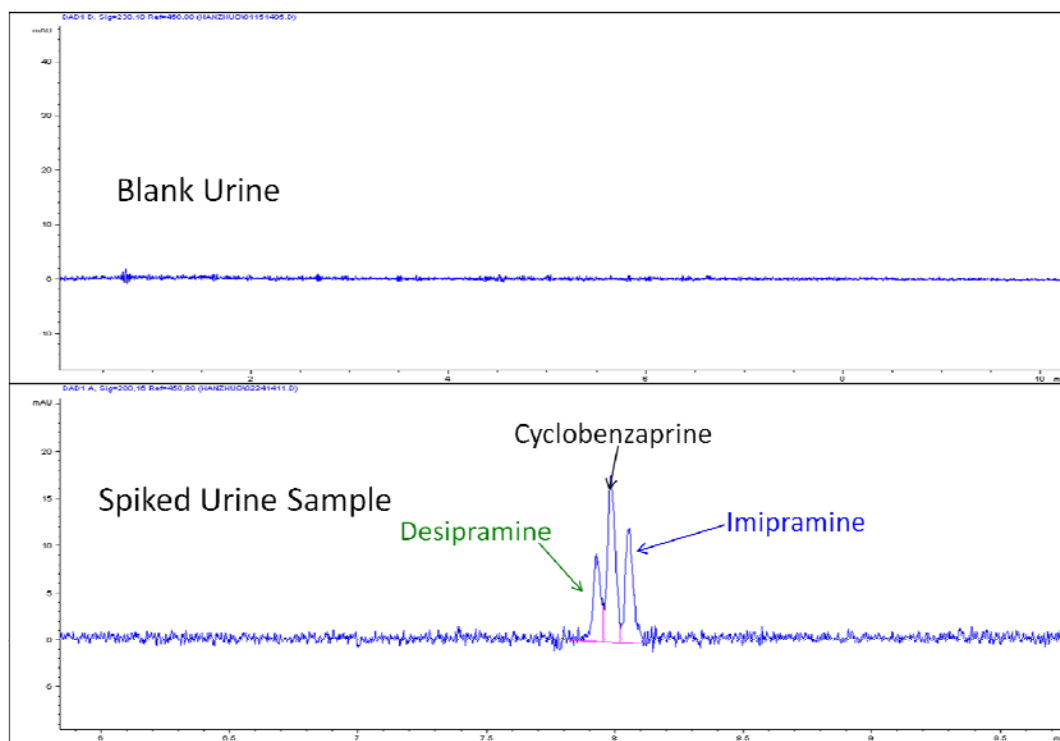

Figure 2.9 Electropherogram of TOP: Blank urine samples and BOTTOM: spiked urine samples of a mixture of three compounds at the concentration of 100 ng/mL. BGE: ACN:Phosphate Buffer 30:70. Run voltage: 30 kV. Injection: 5 s at 10 kV. Cassette temperature: 25 °C.

A spiked urine sample containing three analytes were examined and the results using UV detector are presented as Figure 2.9. A comparison between blank urine and the spiked urine samples were. The top figure of Figure 2.9 is shown extraction of blank urine sample. No signal was obtained, which matches the character of the blank urine. The bottom figure of Figure 2.9 is the spiked urine sample exhibiting three analytes cyclobenzaprine, desipramine and imipramine were separated and captured by UV (DAD) detector.

The spiked urine sample was then infused into the TOF-MS system in order to check the extraction capability. The results are presented as Figure 2.10.

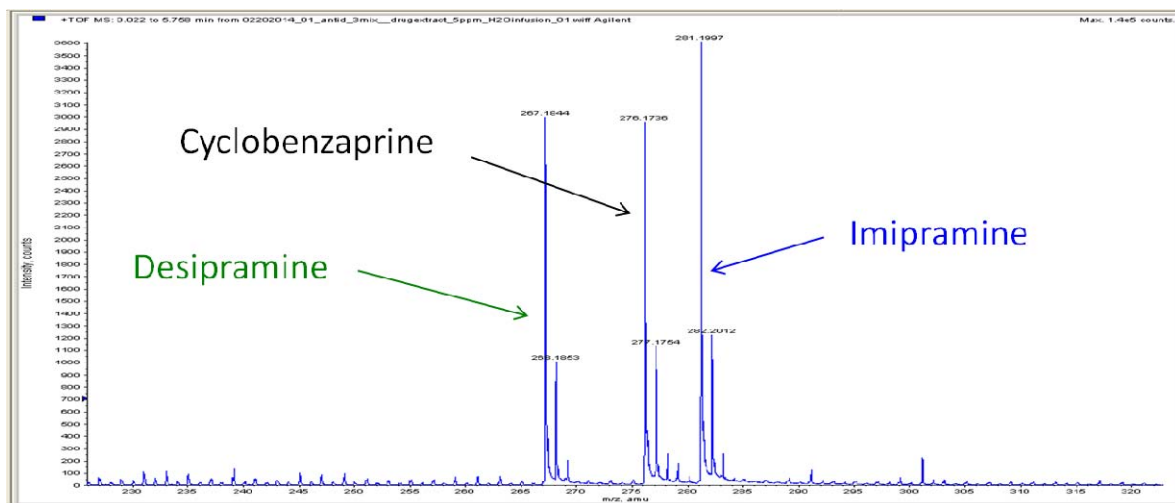

Figure 2.10 Mass spectrum of spiked urine sample of a mixture of three compounds at the concentration of 100 ng/mL. Three compounds were identified by TOF-MS. M+H values as Table 2.5. Detection conditions were same as Figure 2.9.

Exact molecular weight information was obtained for the three antidepressant analytes spiked in the sample. Since the TOF is an accurate mass detector, four decimal places molecular weight information was given.

Table 2.5 Accurate mass measurements of extracted urine samples (n≥5)

Compound	Formula	M (calculate)	M+H (calculated)	M+H (experimental)	Error (amu)	Error (ppm)
Cyclobenzaprine	C ₂₀ H ₂₁ N	275.1669	276.1747	276.1736	-0.0011	-4
Desipramine	C ₁₈ H ₂₂ N ₂	266.1778	267.1856	267.1844	-0.0012	-4
Imipramine	C ₁₉ H ₂₄ N ₂	280.1934	281.2012	281.1997	-0.0015	-5

Table 2.5 demonstrated the mass measurements of the urine sample extractions. Errors in terms of amu and ppm were calculated and presented in the table. Low errors (ppm) were obtained, which exhibited the advantages of the TOF-MS system.

2.4 Concluding Remarks

This chapter details a method for separation and identification of six antidepressant compounds using an acrylate-base porous monolith capillary. Capillary electrochromatography (CEC) coupled with UV detector was explored. The CEC-UV method provides an effective and efficient method for the separation and identification of the analytes. Spiked urine samples were utilized to check method capability. A liquid-liquid extraction procedure was established to perform sample extraction. Time-of-flight mass spectrometry was also employed for spiked urine sample analysis, and accurate molecular information was obtained.

CHAPTER 3 CHIRAL SEPARATION OF CATHINONE ANALOGS BY CYCLODEXTRIN-ASSISTED CAPILLARY ELECTROPHORESIS

3.1 Introduction

In recent years, there has been a trend towards marketing novel synthetic drug analogs as an alternative to conventional controlled substances [87]. Inexpensive organic starting materials, inadequate control by law enforcement, and rapid transportation of these compounds have led to the widespread use of such drugs. In addition, the increasing use of the Internet makes selling new drugs easier than ever before [88, 89]. According to the European Monitoring Centre for Drugs and Drug Addiction (EMCDDA), mephedrone and related substances are primarily sold online and prices ranged between 18 and 25 Euros for one gram in 2011 [90]. According to the World Drug Report 2013 [30], synthetic cathinones have stimulant effects and are controlled substances in most countries. These categories of synthetic drugs are often referred as new psychoactive substance (NPS) by UNODC, such as mephedrone and methylenedioxypropylvalerone (MDPV). The abuse of synthetic cathinones, also known as “bath salts” (cathinone-type substances such as mephedrone and methylenedioxypropylvalerone(MDPV)), has become a major public health threat across the world [30]. Case reports and clinical studies have shown that the use of these designer drugs can cause severe psychiatric symptoms and possibly death [91-93]. In USA, the chemicals used in “bath salts” were under Federal control and regulation announced by U.S. DEA in 2011 as “an increasing number of reports from poison control centers,

hospitals and law enforcement regarding products containing one or more of these chemicals” [94] was received. Strictly control should be implemented and it is necessary to analyze and detect cathinone analogs for forensic applications.

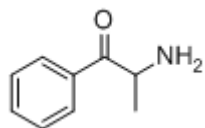
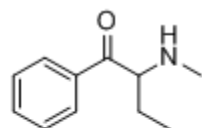
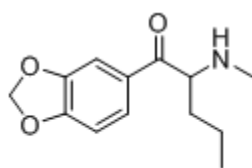

Figure 3.1a Structure of cathinone



Buphedrone



Pentylone

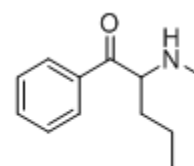

Pentedrone

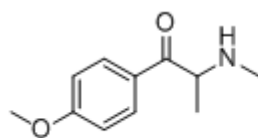

Methedrone

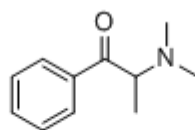

Dimethylcathinon

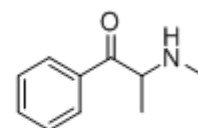

Ethcathinone

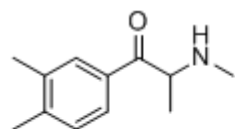

3,4-Dimethylmethcathinone

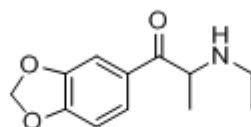

Ethylone

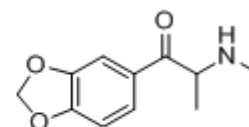

Methylone

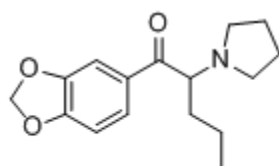

Methylenedioxypropylone

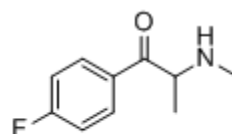

4-Fluoromethcathinone

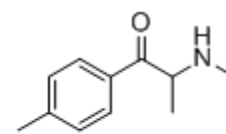

Mephedrone

Figure 3.1b Structures of all cathinones used in Chapter 3

Though the first synthetic cathinones, methcathinone and mephedrone, were introduced in the late 1920s, many related compounds have been synthesized [95]. Since then, however, most of these have not been used for clinical purposes because of serious side effects. Cathinone analogs are amphetamine-like psychostimulants, structurally related to the main psychoactive component of the katha plant (*Catha edulis*), the phenylpropylamine alkaloid cathinone (Figure 3.1a) [96].

Cathinone analogs are a group of β -keto phenethylamine compounds that are derived from the parent compound cathinone shown in Figure 3.1a [97]. Analogs studied in Chapter 2 are illustrated in Figure 3.1b.

Because of existence of a chiral center in cathinone analog compounds, two isomers exist for each drug [98]. As with many chiral active pharmaceutical ingredients, the pharmacological effect of the enantiomers of those psychoactive compounds can differ [99-101]. The enantiomeric separation of cathinone analogs may become important as these isomers can perform different functions in drug design and other aspects.

Many different types of instrumentation and methods have been utilized for the separation of cathinone analogs, including HPLC [102-104], GC [99, 105, 106], and CE [107-110]. Compared to HPLC and GC, CE demonstrates numerous advantages including high efficiency and resolution, and the capability to perform chiral separations through the addition of chiral selectors to the background electrolyte (BGE). The chiral selector procedure allows easy and fast preparation compared to the required modifications of the stationary phase necessary in CEC, HPLC, and GC chiral separation [83, 111]. In addition, CE permits low sample injection sizes which are a benefit when

sample volumes are limited in most forensic case applications [112]. Capillary electrophoresis has been used for cathinone detection, for example, in 2012, Mohr *et al.* [107] described a method of enantioseparation of 19 cathinone derivatives with sulfated- β -CD. However they did not apply mass spectrometric detection to these samples, which is a necessary step in forensic case study as a confirmatory method.

A major advantage of capillary electrophoresis over other separation techniques is its capability of separation in the area of chiral analysis [107-110, 113]. Furthermore, the technique has wide applications in forensic toxicology, as demonstrated by the numerous papers published in the field by Fanali, Lurie, and others [109, 113-116]. In this project presented in Chapter 3, the capability of CE has been investigated in the determination of synthetic cathinone analogs. With CE, numbers of chiral selectors are available for use, including crown ether [117-127] and antibiotics [128-135]. Among them, cyclodextrins (CDs) and their analogs are the most commonly used [107, 136].

Compared to other chiral selectors, cyclodextrin has its own advantages: i. it is relatively cheaper than crown ether [137], which is another widely used chiral selector; ii. CD has a low UV signal shield at 200-250 nm, which is especially useful for the target compounds used in this project; and iii. it is easy to synthesize CD derivatives on the basis of CD's neutral α -, β - and γ -CD forms since the OH- groups on the edge of CD ring provide various anchoring sites. However, cyclodextrin is a non-volatile compound, which means once it gets into the MS ionization source, it is difficult to remove. In this case, other than spraying buffer containing the CD directly into the MS, a novel approach

should be implemented for CE coupling with MS. This part (CE-MS) will be mainly discussed in the next chapter (Chapter 4). Chapter 3 is focused on CE-UV mode.

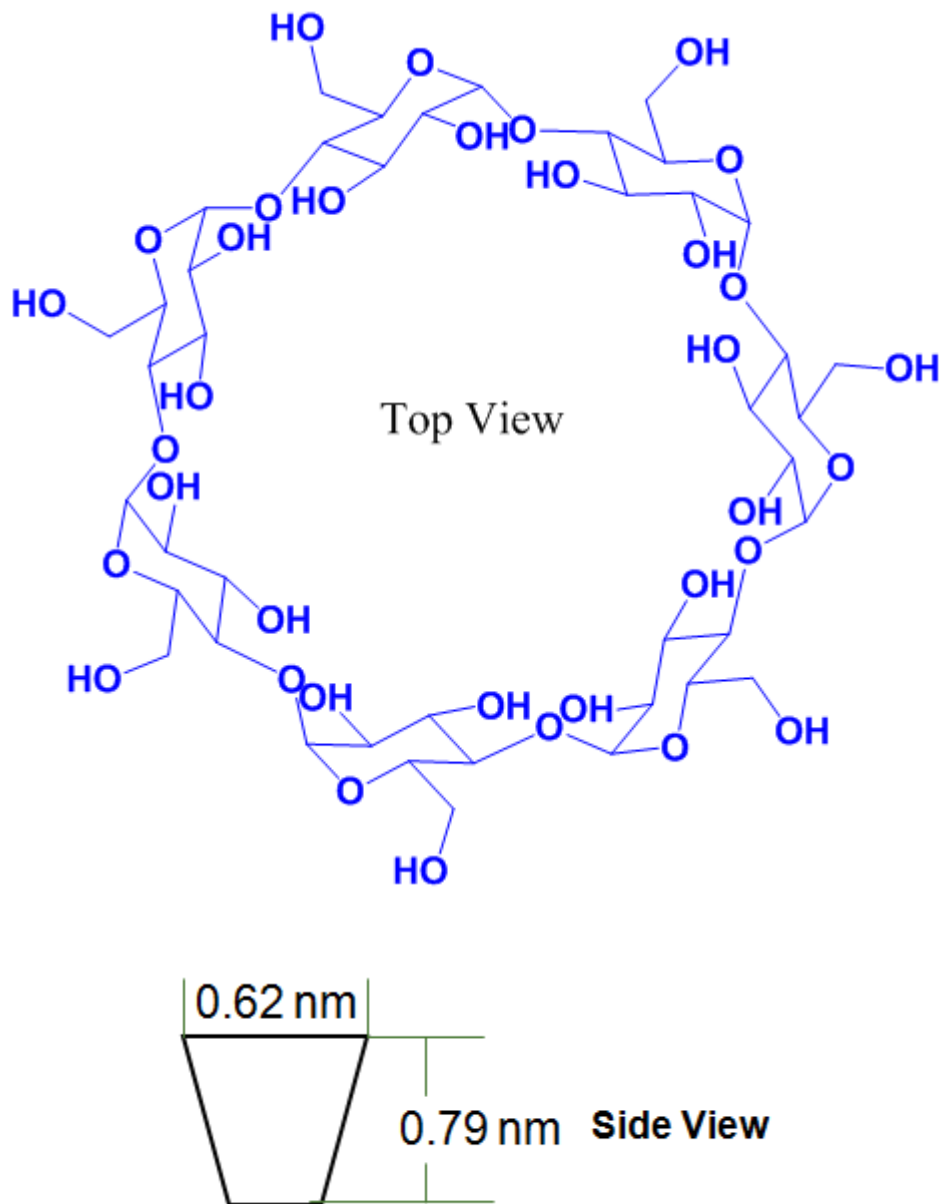

Figure 3.2 TOP: The structure of β -cyclodextrin from top view and BOTTOM: Side view with diameter and height values of β -cyclodextrin molecule.

The possible separation mechanism of CD was proposed by Prof. Bezhan Chankvetadze of Tbilisi State University [138]. He concluded that "... in order to be separated by CE, the enantiomers must migrate with different velocities along the longitudinal axis of a separation capillary" [138], and to accomplish such goal, it is necessary to add the chiral selector to BGE. The mechanism is expressed as the following equation:

Equation 3.1 Separation mechanism of CD proposed by Chankvetadze [138]

$$\Delta\mu = \frac{(\mu_f - \mu_c)(K_S - K_R)[C]}{1 + (K_R + K_S)[C] + K_R K_S [C]^2}$$

where $\Delta\mu$ represents the velocity difference between isomers of the same chiral analyte, μ_f and μ_c are mobility of the non-complex form and mobility of complex form, respectively. The variable $[C]$ represents the concentration of chiral selector, and the complexation constants of R and S isomers are expressed as K_R and K_S . Equation 3.1 explains that when the two enantiomers react with CD and the diastereometric products have their own velocity and enantiomers-chiral selector complexation constants, a velocity difference between the two enantiomers exists, so the two enantiomers elute out the capillary at different migration times.

In 1997, another assumption was proposed, that even when $K_R = K_S = K$, chiral separation can be achieved by CE. In this scenario, Equation 3.1 is transformed to the following equation.

Equation 3.2 Separation mechanism of CD when association constants are at the same value [138].

$$\Delta\mu = \frac{(\mu_{cR} - \mu_{cS})K[C]}{1 + K[C]}$$

The goal of the particular project presented in Chapter 3 was to develop a method for simultaneous chiral analysis of multiple cathinone analogs by cyclodextrin-assisted CE. In addition, the author was interested in developing a procedure to permit coupling the chiral separations with time of flight mass spectrometry (TOF-MS). In this way one could also obtain the exact mass information useful in compound detection and identification by the TOF-MS. In Chapter 3, the CE-UV part of the project is mainly discussed. Detailed experimental procedures and method development of CE-TOF-MS section will be demonstrated in Chapter 4.

3.2 Experimental

3.2.1 Chemicals

Phosphoric acid and acetic acid were purchased from Fisher Scientific (Pittsburgh, PA, USA); ammonium acetate, sodium hydroxide, sulfated β -cyclodextrin, highly sulfated- β -cyclodextrin, and sodium phosphate monobasic monohydrate from Sigma-Aldrich (St. Louis, MO, USA); β -cyclodextrin and γ -cyclodextrin from TCI America (Portland, OR, USA); and highly sulfated γ -cyclodextrin from Beckman Coulter (Brea, CA, USA). Distilled water was produced with a Barnstead Nanopure Diamond water

system (Waltham, MA, USA). Sodium phosphate dibasic heptahydrate were obtained from Acros Organics (Morris Plains, NJ, USA).

Acetonitrile (ACN), methanol (MeOH), Isopropanol, and phosphoric acid used for the preparation of the buffer electrolytes, were of analytical reagent grade (Carlo Erba, Milan, Italy). Distilled water was deionized by a Milli-Q water purification system (Millipore, Bedford, MA, USA).

A number of experiments were performed in the author's Italian collaborator's lab. For method development in the Italian lab facility (UV/Vis detection), drug standards of (±)-2-(methylamino)-1-phenylbutan-1-one hydrochloride (Buphedrone), (±)-1-phenyl-2-(methylamino)pentan-1-one hydrochloride (Pentedrone), (±)-1-(4-methoxyphenyl)-2-(methylamino)propan-1-one hydrochloride (Methedrone), (±)-1-(3,4-dimethylphenyl)-2-(methylamino)propan-1-one hydrochloride (3,4-DMMC), (±)-2-ethylamino-1-phenylpropan-1-one hydrochloride (Ethcathinone), (±)-1-(4-fluorophenyl)-2-methylaminopropan-1-one hydrochloride (4-Fluoromethcathinone), (±)-2-dimethylamino-1-phenylpropan-1-one hydrochloride (Dimethylcathinone), (±)-2-methylamino-1-(3,4-methylenedioxyphenyl)propan-1-one hydrochloride (Methylone), (±)-1-(1,3-benzodioxol-5-yl)-2-(ethylamino)propan-1-one hydrochloride (Ethylone), (±)-2-methylamino-1-(4-methylphenyl)propan-1-one hydrochloride (Mephedrone), (±)-1-(1,3-benzodioxol-5-yl)-2-(methylamino)pentan-1-one hydrochloride (Pentylone), (±)-1-(Benzo[d][1,3]dioxol-5-yl)-2-(pyrrolidin-1-yl)pentan-1-one hydrochloride (MDPV) and (±)-2-(ethylamino)-1-phenyl-1-propanone hydrochloride (Ethcathinone) were purchased from LGC Standards (Sesto San Giovanni, Milan, Italy).

For method development in USA lab facility (UV/Vis and CE/MS) at FIU, drug standards of (±)-2-(methylamino)-1-phenylbutan-1-one (Buphedrone), (±)-1-phenyl-2-(methylamino)pentan-1-one (Pentedrone), (±)-1-(4-methoxyphenyl)-2-(methylamino)propan-1-one (Methedrone), (±)-1-(3,4-dimethylphenyl)-2-(methylamino)propan-1-one (3,4-DMMC), (±)-2-ethylamino-1-phenyl-propan-1-one (Ethcathinone), (±)-1-(4-fluorophenyl)-2-methylaminopropan-1-one (4-Fluoromethcathinone), (±)-2-dimethylamino-1-phenylpropan-1-one (Dimethylcathinone), (±)-1-(1,3-benzodioxol-5-yl)-2-(ethylamino)propan-1-one (Ethylone), (±)-1-(1,3-benzodioxol-5-yl)-2-(methylamino)pentan-1-one (Pentylone), and (±)-2-(ethylamino)-1-phenyl-1-propanone, monohydrochloride (Ethcathinone) were purchased from Cayman Chemical (Ann Arbor, MI, USA) and drug standards of (±)-2-methylamino-1-(4-methylphenyl)propan-1-one (Mephedrone), (±)-1-(Benzo[d][1,3]dioxol-5-yl)-2-(pyrrolidin-1-yl)pentan-1-one (MDPV) and (±)-2-methylamino-1-(3,4-methylenedioxyphenyl)propan-1-one (Methylone) were purchased from Lipomed (Cambridge, MA, USA). The chemical structures of cathinones are represented in Figure 1b.

Stock solutions of synthetic cathinones (0.1 mg/mL) were prepared in methanol and stored at -20 °C. Background electrolytes (BGE) used for CE experiments were prepared daily by dissolving the proper amount of β-cyclodextrins in phosphate buffer. All the electrolyte solutions for the CE separation were stored in glass bottles at + 4 °C.

Background electrolyte preparation

Phosphate buffers were prepared by diluting concentrated phosphoric acid to a desired concentration, in this project to a 100 mM phosphate buffer and adjusting with a 1.0 M NaOH solution in order to reach the working pH (= 2.5). In the experiments evaluating the influence of the pH on separation performance, 100 mM solutions of phosphoric acid at the starting pH of 1.8 were titrated with NaOH (1.0 M) to match pHs of 2.5, 3.5, 5.0 and 7.0.

3.2.2 Instrumentation

The separation experiments of cathinone standards and commercial samples were performed using a fully automated capillary electrophoresis system (G1600, Agilent Technologies, Santa Clara, CA, USA) with the column temperature maintained at 25 °C. Separations were performed in 50 µm ID uncoated fused silica capillaries with a total length of 57.5 cm and an effective length of 49.5 cm. The capillary columns were obtained from Polymicro (Phoenix, AZ, USA). Prior to use, each new capillary was rinsed with 1.0 M NaOH for 25 min and water for 10 min as the pretreatment steps. Samples were introduced into the capillary using electrokinetic injection for 10s at 10 kV. CE-UV detection was performed via on-column measurements using a diode array detector (DAD) at a wavelength of 206 nm. Experiments were carried out in “normal polarity” mode (anode at the capillary inlet) by applying a constant voltage of 25 kV during analyses with the current at ~52 µA.

3.3 Results and Discussion

3.3.1 Method development and CE-UV results

In this CE-UV study the cathinones examined belong to the benzoylethanamines class. These compounds have similar chemical structures differing from each other by presence of different substituents that may include halogen, dioxol, and alkyl groups. Hence, a highly efficient and selective method for the discrimination of such closely related compounds is needed. From the data reported in the literature, numerous chromatographic methods have been developed for the separation of this class of drugs. [102, 139-141]. However, given the wide variety and potential development of new compounds, there is a need for methods which can access the high efficiency and identification capability that can be obtained via CE and mass spectrometric methods.

The initial conditions for the separation were adapted from a previous study developed in the McCord research group for the separation of amphetamine and piperazine designer drugs [142]. In that project, 6 piperazine and 4 chiral amphetamine compounds were simultaneously separated within 23 min using a 200 mM phosphate buffer at pH=2.8 with 20 mM hydroxypropyl- β -cyclodextrin (HP- β -CD) as a buffer additive. For the analysis of the cathinone analogs in this project, various separation parameters (pH, buffer concentration, field strength, etc.) were further optimized using UV-visible detection prior to coupling the procedure to mass spectrometry.

3.3.1.1 Background electrolyte (BGE) optimization

Different pH conditions were tested at pH 2.5, 3.5, 5.0, and 7.0. It appears that at low pH the resolution was higher, presumably resulting from the reduced electroosmotic flow at low pH conditions. The results shown in Figure 3.3 illustrate the influences of the pH on the resolution and the analysis time. At higher pH conditions the resolution dropped, and coelution of several of the cathinones occurred. pH of 2.5 produced optimal migration times, peak efficiency, and resolution. Buffers at pH lower than 2.5 produced no advantage in terms of resolution of the peaks. Thus, pH of 2.5 was used for all further experiments.

The effect of buffer concentration on the separation was examined at 50 mM, 75 mM, 100 mM and 150 mM phosphate. Among these different concentrations, 100 mM phosphate provided the optimum results in terms of resolution and migration time.

Once the pH and the buffer concentration were optimized, further tests were performed to improve the separation. In particular, the author examined the effect of the addition of 5-20 mM β -cyclodextrin (β -CD) with and without organic modifiers in the buffer (Figure 3.4 and Figure 3.5). The results shown in Figure 3.4 demonstrate that the concentration of the β -CD has a marked effect on both of the resolution and the migration time. Higher concentrations of β -CD resulted in increased migration times due to slower migration of the drug/cyclodextrin complex. Optimal resolution and peak shape occurred at a concentration of 10 mM β -CD. In addition to β -CD, highly sulfated- γ -CD (HS- γ -CD) and mixtures of HS- γ -CD and β -CD were examined (Figure 3.6). In general, the separations obtained from HS- γ -CD separation were not as efficient as those from β -CD.

Higher amounts of HS- γ -CD also lead to raised baselines and a significant drop in signal to noise ratio with UV detection. The effects of 2 %, 5 %, and 10 % of MeCN, MeOH, and isopropanol in the BGE containing 10 mM β -CD were also tested. Bulk migration times were slower when organic modifiers were added to the BGE, and a decrease in the resolution of cathinones was observed. Because of the longer analysis time and the lower resolution, those conditions were not useful. Thus, the final conditions for the separation buffer consisted of 100 mM phosphate at a pH of 2.5 with 10 mM β -CD. This buffer permitted the resolution of all relevant synthetic cathinones as well as the chiral separation of 10 of them (Figure 3.7). These buffer conditions compare favorably with a previous chiral separation of some of these compounds and uses neutral β -CD as a modifier [107].

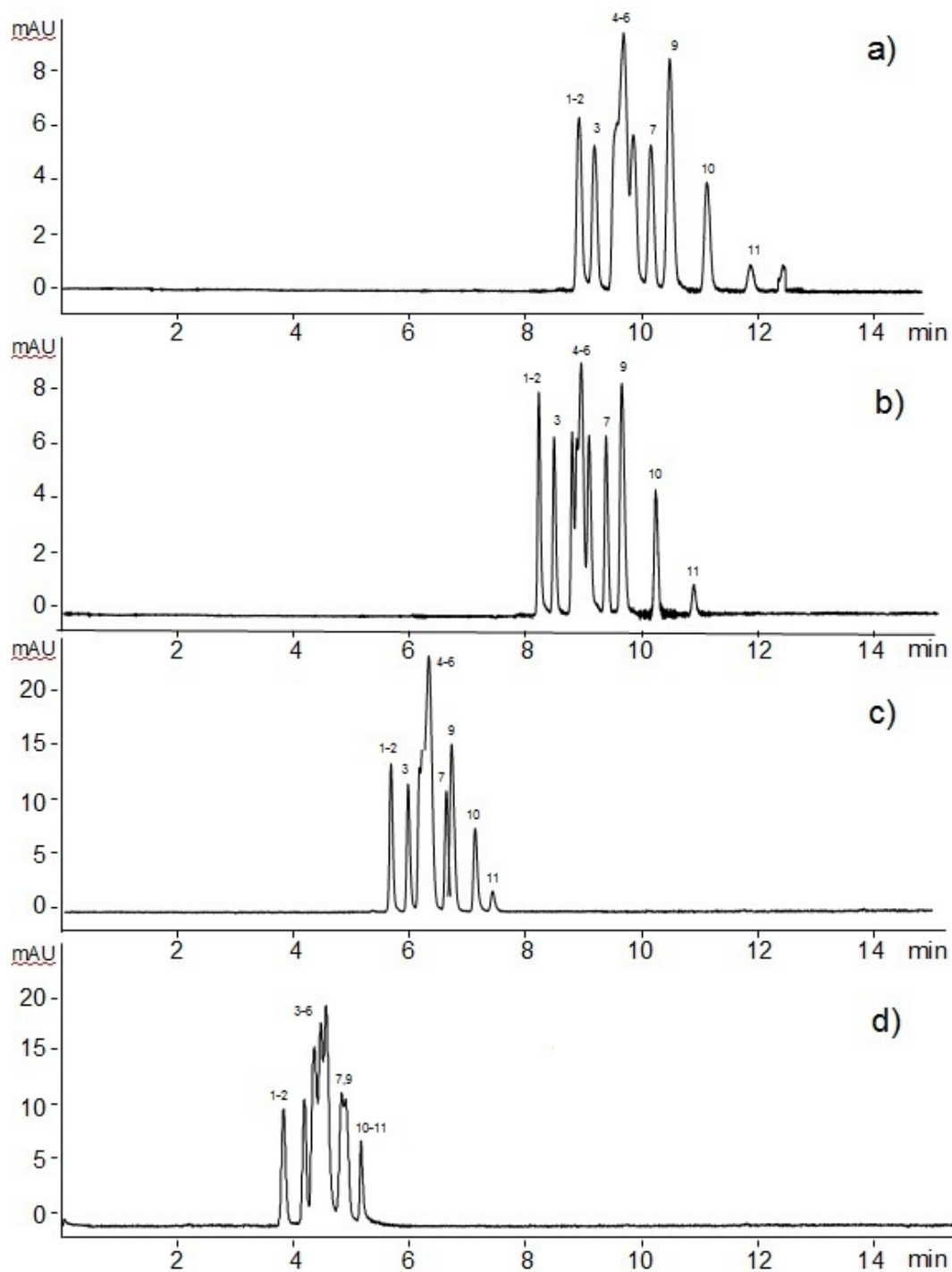

Figure 3.3 Effect of pH value on the separation of the twelve synthetic cathinones. (a) pH 2.5; (b) pH 3.5; (c) pH 5.0; (d) pH 7.0. Conditions: BGE 100 mM phosphate buffer; voltage injection, 10 kV for 10 sec; applied voltage, 25 kV; temperature, 25 °C; fused-silica capillary, 57.5 cm (49.0 cm effective length) x 50 μ m i.d.; detection, 206 nm.

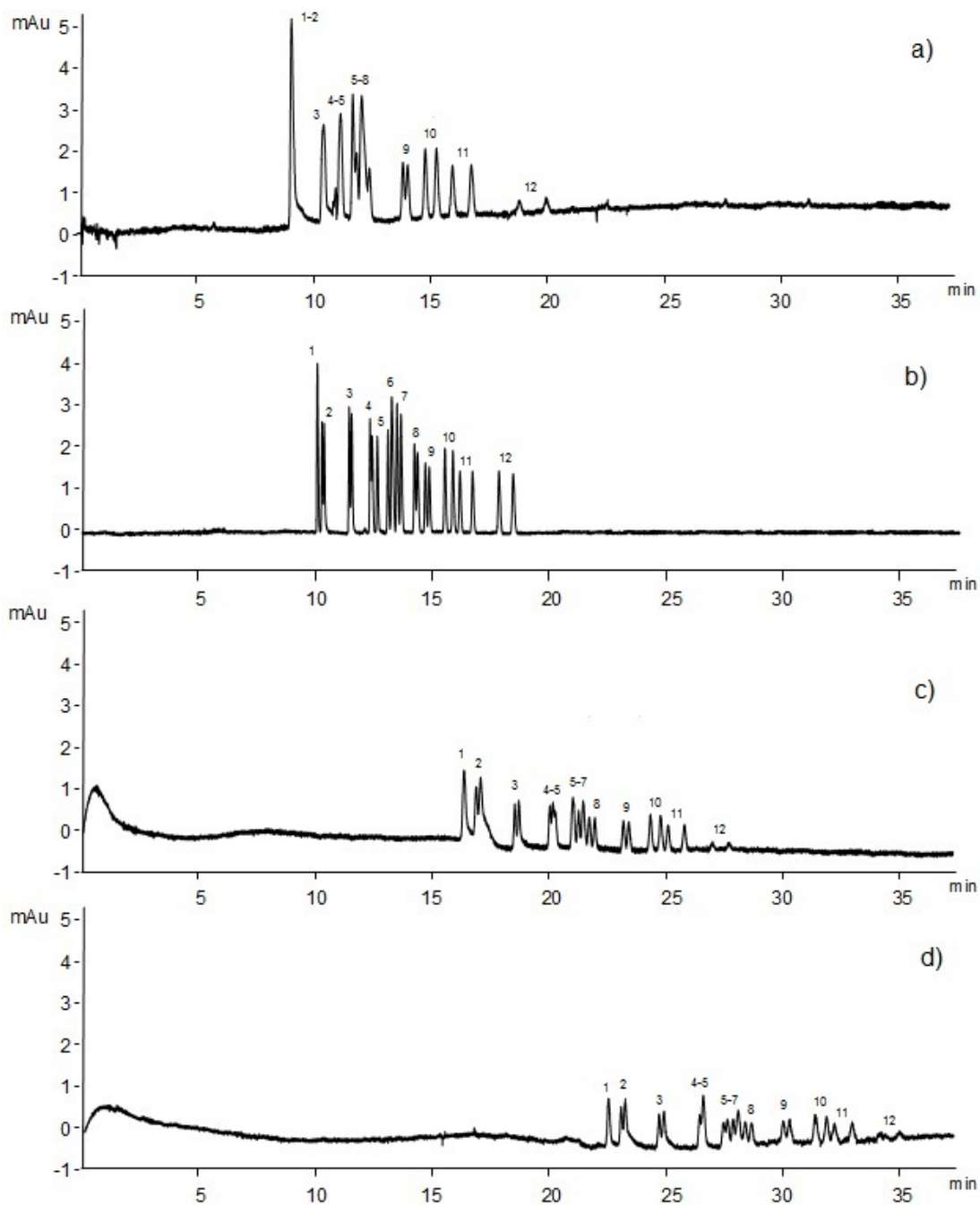

Figure 3.4 Effect of the concentration of β -cyclodextrine on the separation of the twelve cathinones and enantiomers. (a) 5 mM, (b) 10 mM; (c) 15 mM and (d) 20 mM. Separation conditions as in Figure 3.3.

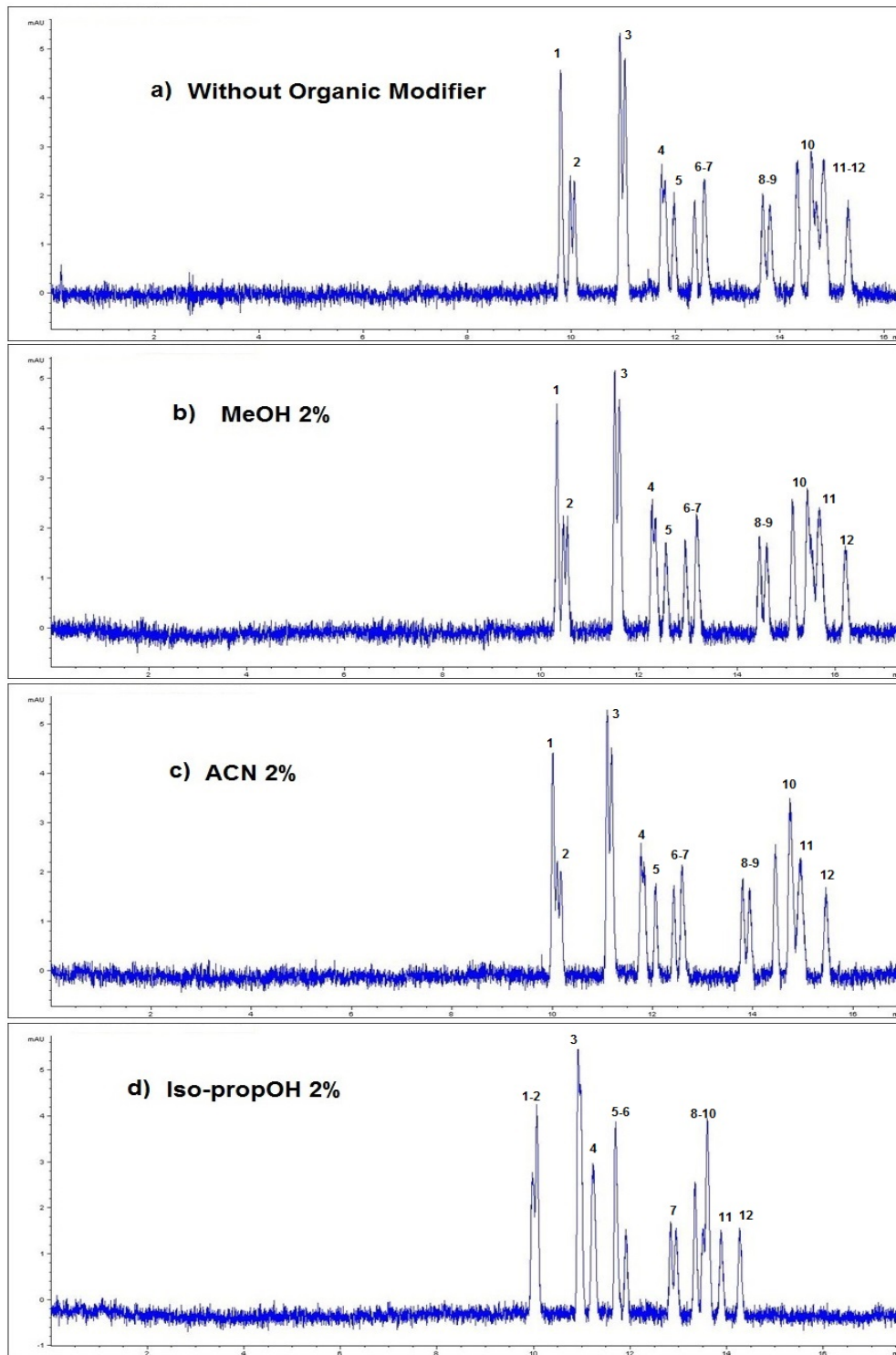

Figure 3.5 Effect of the organic modifier as an addition to the phosphate buffer on the separation of the twelve cathinones and enantiomers. Separation conditions as in Figure 3.3.

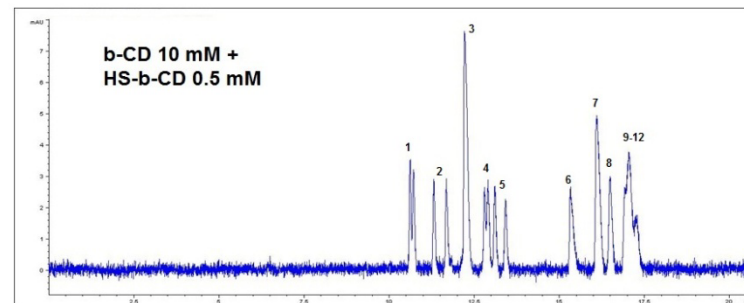
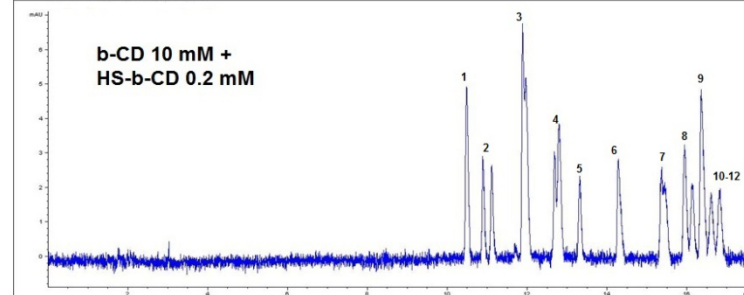
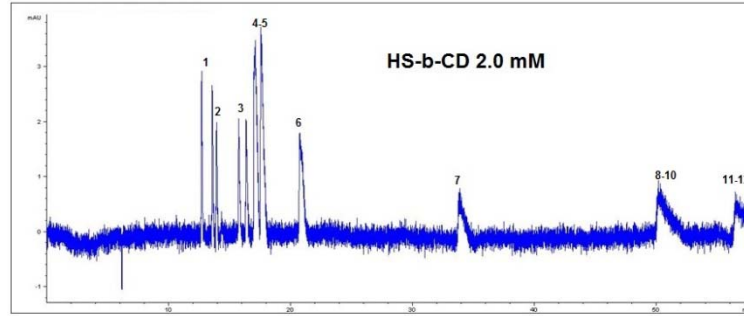
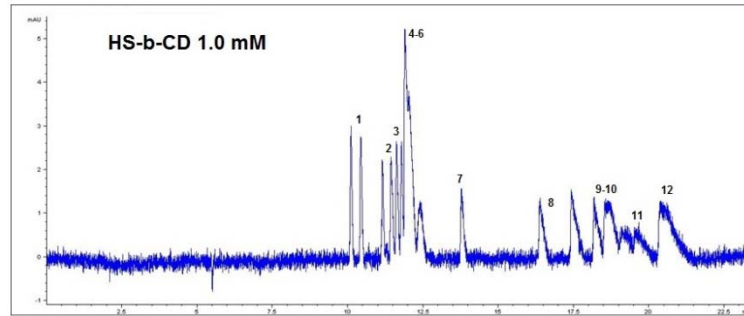
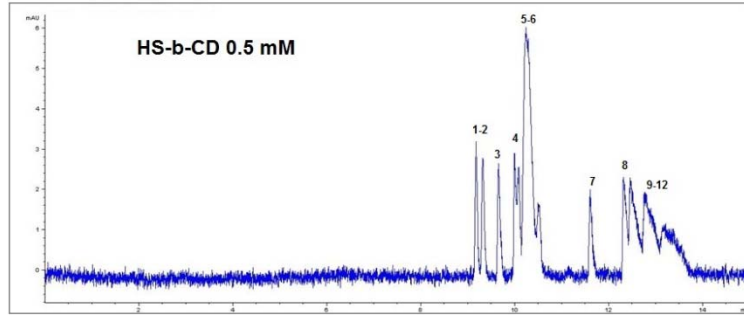

Figure 3.6 Effects of concentration of β -CD and HS- β -CD on the separation of the twelve cathinones and enantiomers. Separation conditions as in Figure 3.3.

3.3.1.2 CE-UV results

Figure 3.7 demonstrates the separation of a standard containing 12 cathinone analogs using this method. The optimal running voltage was 25 kV (435 V/cm). Lower field strengths provided longer migration times and broader peaks, with little improvement in terms of resolution.

The separation conditions utilized were the optimized parameters discussed in previous sections. A mixture of 12 compounds at 100 ng/mL for each individual compound was enantio-separated using a 100 mM phosphate buffer containing 10 mM of β -cyclodextrin at pH 2.5. Electrokinetic injection was used and the sample was injected for 10 s at 10 kV. The running voltage was 25 kV with cartridge temperature set to 25 °C. A fused-silica capillary with 57.5 cm long (49.0 cm effective length) x 50 μ m i.d. was used to carry out the separation. DAD was set to scan at 206 nm.

All compounds except 4-fluoromethcathinone and methedrone showed stereospecific interactions with the chiral selector β -CD. 4-Fluoromethcathinone and methedrone could be distinguished from other compounds but could not be enantio-separated. Interestingly, these two compounds were enantiomerically separated using the highly sulfated- γ -cyclodextrin buffer in CE-MS mode. Thus, the geometry of these molecules may have been a factor affecting the separation of their enantiomers by the different cyclodextrins.

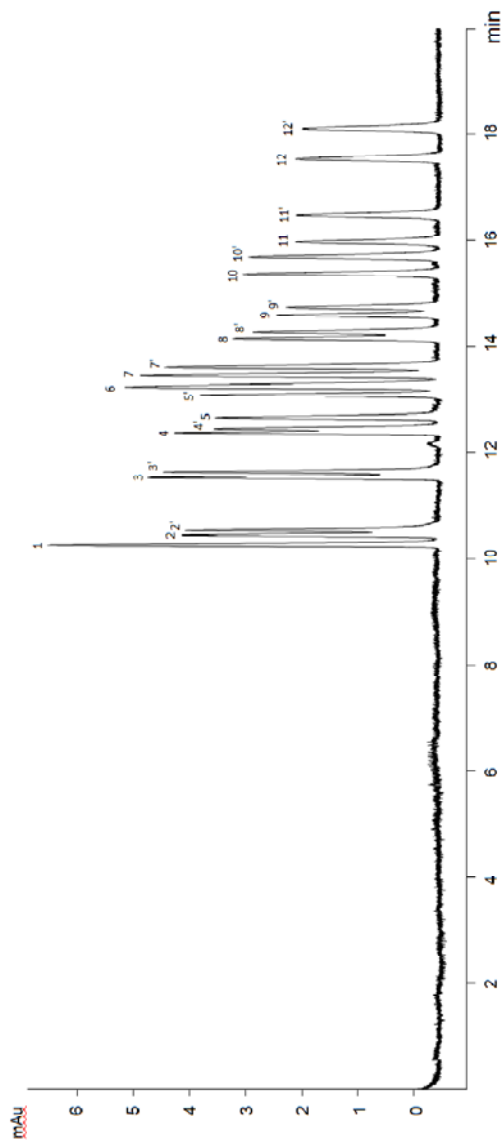

Figure 3.7 Electropherogram of the simultaneous chiral separation of a mixture of 12 compounds at 100 ng/mL, using a 100 mM phosphate buffer adding with 10 mM of β -cyclodextrin. Separation conditions as in Figure 3.3. Peak identification: 4-Fluoromethcathinone (1); Dimethylcathinone (2,2'); Ethcathinone (3,3'); Buphedrone

(4,4'); Pentedrone (5,5'); Methedrone (6); Methylone (7,7'); Mephedrone (8,8'); Ethylone (9,9'); 3,4-DMMC (10,10'); Pentylone (11,11'); MDPV (12,12').

3.3.2 Method validation

Once the optimum conditions for the analysis of cathinones were determined, the method was validated in terms of linearity, precision, limit of detection (LOD), and limit of quantification (LOQ). Linearity of the method was established over the range from 12.5 ng/mL to 500 ng/mL (n=5) with correlation coefficients (r^2) ranging between 0.9911 and 0.9955. Table 3.1 illustrates the analytical figures of merit obtained from the twelve analyzed synthetic cathinones.

The analytical precision was assessed by examining repeated injections of a mixture of cathinones at a concentration of 100 ng/mL. In Table 3.1, inter-day and intra-day precision data, including % RSD, migration time (t_m), and peak areas, are reported as well. The RSD values for retention time were lower than 0.99% for intra-day precision and 1.0% for inter-day precision. Good results were also achieved for peak areas with $RSD \leq 7.6\%$ and 8.5% for intra- and inter-day experiments. To investigate the method sensitivity under the proposed conditions, limits of detection (LOD) and quantification (LOQ) were determined as 3 times and 10 times the signal-to-noise ratio, respectively. The LODs ranging from 4.2 ng/mL to 7.0 ng/mL and LOQs ranging from 13 ng/mL to 21 ng/mL for all selected cathinones were found (results shown in Table 3.1).

Table 3.1. Figures of merit for the CE-UV results of the chiral separation project

Analytes	Linearity		Sensitivity		Precision (Intra-day, n=6)			Precision (Inter-day, 3 d/n=9)	
	Slope	R ²	LOD (ng/mL)	LOQ (ng/mL)	t _R (RSD%)	Peak area (RSD%)	t _R (RSD%)	Peak area (RSD%)	
4-Fluoromethcathinone	0.2153	0.9955	5.9	18	0.83	4.52	0.99	6.85	
Dimethylcathinone	0.2874	0.9943	5.6	17	0.83	4.55	0.98	7.13	
Ethcathinone	0.2291	0.9949	4.9	15	0.91	5.98	1.0	8.47	
Buphedrone	0.2584	0.9939	5.4	16	0.98	3.31	1.0	6.27	
Pentadrone	0.2026	0.9916	7.0	21	0.98	5.64	1.0	8.01	
Metfedrone	0.2205	0.9927	6.5	19	0.93	4.86	0.99	6.69	
Mettylone	0.2511	0.9926	5.1	15	0.99	7.60	1.0	6.69	
Mephedrone	0.2232	0.9912	5.8	18	0.89	5.01	0.98	7.64	
Etiylone	0.2315	0.9911	6.1	18	0.90	7.44	0.94	8.32	
3,4-DNMC	0.3668	0.9944	4.2	13	0.87	6.68	0.90	7.44	
Pentylone	0.2373	0.9937	6.1	18	0.78	2.68	0.88	5.12	
MDFV	0.2412	0.9927	5.6	17	0.70	5.60	0.86	7.87	

3.4 Concluding Remarks

This chapter details the development of an optimized method for the separation of 12 cathinone analogs using β -cyclodextrin for the CE-UV detection. Separations were carried out in 50 μm ID uncoated fused silica capillaries with a total length of 57.5 cm and an effective length of 49.5 cm. Electrokinetic injection mode was used for sample injection with conditions of 10 kV and 10 s. Running voltage was set to 30 kV. Various parameters were tested to obtain optimum separation results, including different chiral selectors, buffer concentrations, pH of the buffer, and organic modifiers. The β -CD was selected and optimum separation results were achieved using 100 mM phosphate buffer containing 10 mM of β -CD. All 12 cathinone analogs were separated with 10 out of 12 enantio-separated.

The method provides high resolution separation by CE-UV. The protocol was validated by running various standards intra- and inter- day. The low injection volume permitted by CE will make this method useful in forensic laboratories when a minimal sample input is required.

CHAPTER 4 IDENTIFICATION OF CATHINONE ANALOGS BY TIME-OF-FLIGHT MASS SPECTROMETRY

4.1 Introduction

Mass spectrometry (MS) is a technique that provides mass spectra information on atoms or molecules. In this study, I would like to take advantage of MS to identify the analytes in the project. Several factors are considered. The most vital step is to avoid ionization source contamination. To achieve the goal, partial filling technique was used. Partial-filling micellar electrokinetic chromatography (PF-MEKC) was first introduced by Terabe *et al.* [19] and provides a potential solution for interfacing chiral MEKC separations with ESI-MS. In comparison with conventional MEKC, PF-MEKC involves filling a small portion of the capillary with a micellar solution to achieve a separation. The capillary in PF-MEKC is filled with electrophoresis buffer, followed by the introduction of micellar solution and finally a sample injection. In PF-MEKC, the analytes first migrate into the micellar plug where the separation occurs and then into the electrophoresis buffer, which is free of surfactant. The analytes in the electrophoresis buffer sequentially elute out of the MEKC capillary and are subsequently introduced into ESI-MS, while the surfactant plug remains behind in the capillary. Once the analytes are detected by the mass spectrometer, electrophoresis is terminated to avoid the surfactant plug eluting into the detector. The partial filing technique has proven to be a very useful procedure to prevent nonvolatile chiral selectors entering into the MS. However, it requires a complex series of steps to avoid MS contamination. Molina *et al.* [143]

reported three ways to couple micellar electrokinetic chromatography (MEKC) on-line with electrospray ionization mass spectrometry (ESI-MS) for the analysis of N-methylcarbamate pesticides. A more stable electrospray performance was obtained; however, some of the analytes were protonated and could not be detected due to the increase in their retention factors.

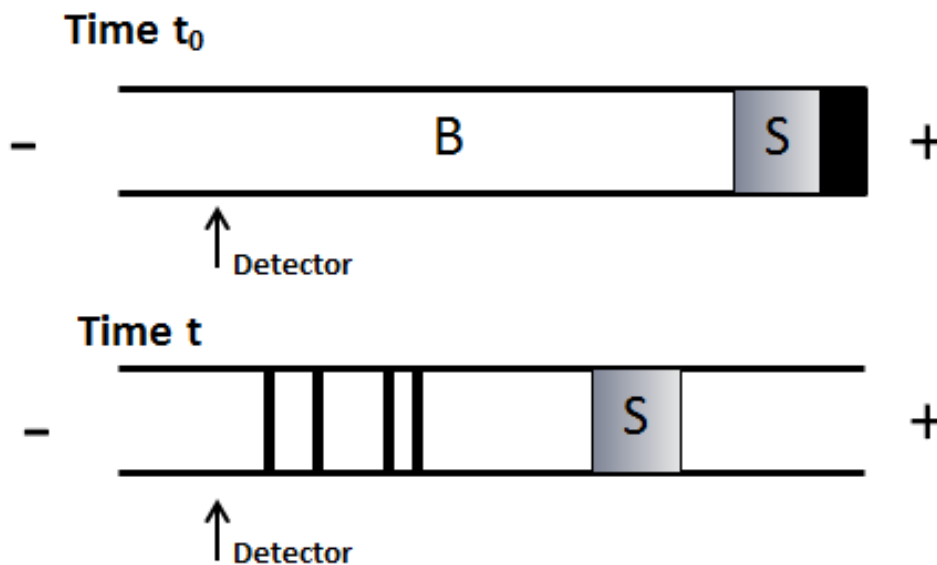

Figure 4.1 Schematic view PF-MEKC (B) Background electrophoresis buffer; (S) surfactant in background electrophoresis buffer. Adapted from Ref. [144].

Although novel MEKC-based methodologies have recently been proposed for chiral analysis, the combination of MEKC methods with MS detection still has some critical issues. One of the main limitations of this coupling is the lack of compatibility of the most widely used surfactants in MEKC separation with mass spectrometers [143]. Generally, surfactant monomers suppress the ionization of the analyte in the spray chamber, which in turn, provides an increased chemical noise in the electrosprays, reducing the sensitivity of the whole MS analysis. In last few years the use of high-

molecular-mass micelle polymers (also referred to as micelle polymers or molecular micelles) as pseudo-stationary phase have been shown to be an interesting alternative to more conventional micelles for the analysis of enantiomers with MS. Further investigation of PF-MS will be examined to see if such materials would be appropriate for trace drug detection and chiral analysis.

4.2 Experimental

4.2.1 Chemicals and materials

Phosphoric acid and acetic acid were purchased from Fisher Scientific (Pittsburgh, PA, USA); ammonium acetate, ammonium dihydrogen phosphate, ammonium formate, sodium phosphate monobasic monohydrate, and sodium hydroxide from Sigma-Aldrich (St. Louis, MO, USA); β -cyclodextrin from TCI America (Portland, OR, USA); and highly sulfated γ -cyclodextrin from Beckman Coulter (Brea, CA, USA). Sodium phosphate dibasic heptahydrate were obtained from Acros Organics (Morris Plains, NJ, USA). Development of capillary electrophoresis as part of a micro-total analytical system for microcystins

Acetonitrile (ACN), methanol (MeOH), Isopropanol, and phosphoric acid used for the preparation of the buffer electrolytes, were of analytical reagent grade (Carlo Erba, Milan, Italy). Distilled water was deionized by a Milli-Q water purification system (Millipore, Bedford, MA, USA).

Drug standards of (\pm)-2-(methylamino)-1-phenylbutan-1-one (Buphedrone), (\pm)-1-phenyl-2-(methylamino)pentan-1-one (Pentedrone), (\pm)-1-(4-methoxyphenyl)-2-

(methylamino)propan-1-one (Methedrone), (\pm)-1-(3,4-dimethylphenyl)-2-(methylamino)propan-1-one (3,4-DMMC), (\pm)-2-ethylamino-1-phenyl-propan-1-one (Ethcathinone), (\pm)-1-(4-fluorophenyl)-2-methylaminopropan-1-one (4-Fluoromethcathinone), (\pm)-2-dimethylamino-1-phenylpropan-1-one (Dimethylcathinone), (\pm)-1-(1,3-benzodioxol-5-yl)-2-(ethylamino)propan-1-one (Ethylone), (\pm)-1-(1,3-benzodioxol-5-yl)-2-(methylamino)pentan-1-one (Pentylone), and (\pm)-2-(ethylamino)-1-phenyl-1-propanone, monohydrochloride (Ethcathinone) were purchased from Cayman Chemical (Ann Arbor, MI, USA) and drug standards of (\pm)-2-methylamino-1-(4-methylphenyl)propan-1-one (Mephedrone), (\pm)-1-(Benzo[d][1,3]dioxol-5-yl)-2-(pyrrolidin-1-yl)pentan-1-one (MDPV) and (\pm)-2-methylamino-1-(3,4-methylenedioxyphenyl)propan-1-one (Methylone) were purchased from Lipomed (Cambridge, MA, USA). The chemical structures of cathinones are represented in Figure 2.1b.

4.2.2 Background electrolyte preparation

Phosphate buffers were prepared by weighing out appropriate amount of sodium phosphate monobasic monohydrate salt and sodium phosphate dibasic heptahydrate salt to pH at 4.5, 6.0, 7.0, and 8.0. For low pH conditions, phosphate buffers were prepared by diluting concentrated phosphoric acid to a 100 mM phosphate buffer and adjusting pH with a 1.0 M NaOH solution in order to reach the desired pH to 2.5 and 3.5.

4.2.3 Sample preparation

Stock solutions of synthetic cathinones (0.1 mg/mL) were prepared in methanol and stored at -20 °C. Background electrolytes (BGE) used for CE-MS experiments were prepared daily by dissolving the proper amount of highly sulfated γ -cyclodextrins in phosphate buffer. All the electrolyte solutions for the CE-MS separation were stored in glass bottles at + 4 °C.

Seized drug samples were obtained from law enforcement sources previously diluted to an appropriate concentration in methanol (approximately 1mg/mL) and centrifuged to remove insoluble material.

4.2.4 Instrumentation

The separation of cathinone standards and commercial samples was performed using a fully automated CE system (G1600, Agilent Technologies, Santa Clara, CA, USA) with the column temperature maintained at 25 °C. Separations were performed in 50 μ m ID uncoated fused silica capillaries with a total length of 80 cm. The capillary columns were obtained from Polymicro (Phoenix, AZ, USA). Each new capillary was rinsed with 1.0 M NaOH for 25 min and water for 10 min. Samples were introduced into the capillary using electrokinetic injection for 10s at 10 kV. Experiments were carried out in “normal polarity” CE mode (anode at the capillary inlet) by applying a constant voltage of 25 kV during analyses.

The time of flight mass spectrometry (TOF-MS) analysis was performed in the positive ion mode using partial filling technique [145-148] to minimize contamination of

the MS with non-volatile cyclodextrins. The CE system was connected to a TOF-MS, (3250a MSD, Agilent Technologies, Santa Clara, CA, USA) with a CE-ESI-MS sprayer interface. Reference masses obtained from Agilent (G1969-85001 API-TOF reference mass solution kit) including purine at 121.0509 m/z and HP0921 at 922.0098 m/z were added to the sheath flow liquid to calibrate the mass spectrometer. The mass range was set to 100-1000 m/z to include both reference masses. The sheath flow – which was composed of 50:50 (v/v) deionized water and methanol along with reference mass solutions – was provided by an isocratic pump set to a low rate of 0.5 mL/min with a 1:100 split ratio resulting in a net flow of 0.005 mL/min.

Table 4.1 CE-ESI-TOF-MS parameters for chiral analysis of cathinone analogs

Parameter	Value
Capillary Voltage	4000 V
Nebulizer pressure	10 psi
Drying gas	5 L/min
Gas temperature	250 °C
Fragmentor voltage	125 V
Skimmer voltage	40 V
Octapole RF	300 V
TOF/PMT	1025 V
Mass range (<i>m/z</i>)	0-1000
Sheath flow	0.5 mL/min
Reference	121.0509, 922.0098

4.3 Results and Discussion

4.3.1 Method development and CE-MS results

To couple the CE with the TOF-MS detector, the capillary was extended to 80 cm in total length to reach the ESI interface. An Agilent Time-of-Flight (G1969A) mass spectrometer was employed for CE-MS detection.

4.3.1.1 Buffer selection

For capillary electrophoresis- mass spectrometry technique, a volatile buffer should be used in order to avoid mass sprayer contamination [149]. Ammonium acetate and ammonium formate were initially tested as background electrolyte because both are volatile and have similar pKa and buffer ranges to the phosphate buffer used in the CE-UV method [149]. However, the separations produced by the ammonium acetate and ammonium formate buffers were poor. Therefore, to maintain acceptable separation results, non-volatile phosphate buffer was adopted; however, the concentration of phosphate buffer was reduced to 50 mM. It should also be noted that this level of buffer was further diluted by the addition of the sheath flow prior to introduction to the mass spectrometer [150, 151]. To further minimize contamination of the mass spectrometer, which was biased in the positive mode, the β -cyclodextrin in the UV separation was replaced by highly sulfated- γ -cyclodextrin [152]. In previous work, highly sulfated γ -cyclodextrin has exhibited good enantiomeric separation ability [153-156] and the highly sulfated form should migrate counter to the osmotic flow in the capillary.

Several parameters, including pH and the concentration of cyclodextrin, were investigated in order to obtain optimal separations. As expected, the optimal pH of 2.5 was similar to that found for the CE-UV. For chiral selection, different amounts of highly sulfated- γ -cyclodextrin were tested starting with 0.2%. Experiment results indicated that 0.6% was the optimum concentration. At concentrations of highly sulfated- γ -cyclodextrin lower than 0.6%, some peaks could not be separated; at concentrations higher than 0.6%, excess noise was present in the extracted ion chromatogram presumably because small amounts of highly sulfated- γ -cyclodextrin entering into electrospray ionization source.

Interestingly, the results using highly sulfated- γ -cyclodextrin produced different separation dynamics. Previously unresolved enantiomeric separations of methadone and fluormethcathinone in CE-UV experiments (Chapter 3) were achieved with the new conditions, while other compounds previously separated as enantiomers such as methylone, dimethyl cathinone, ethcathinone, pentadone and buphedrone were not.

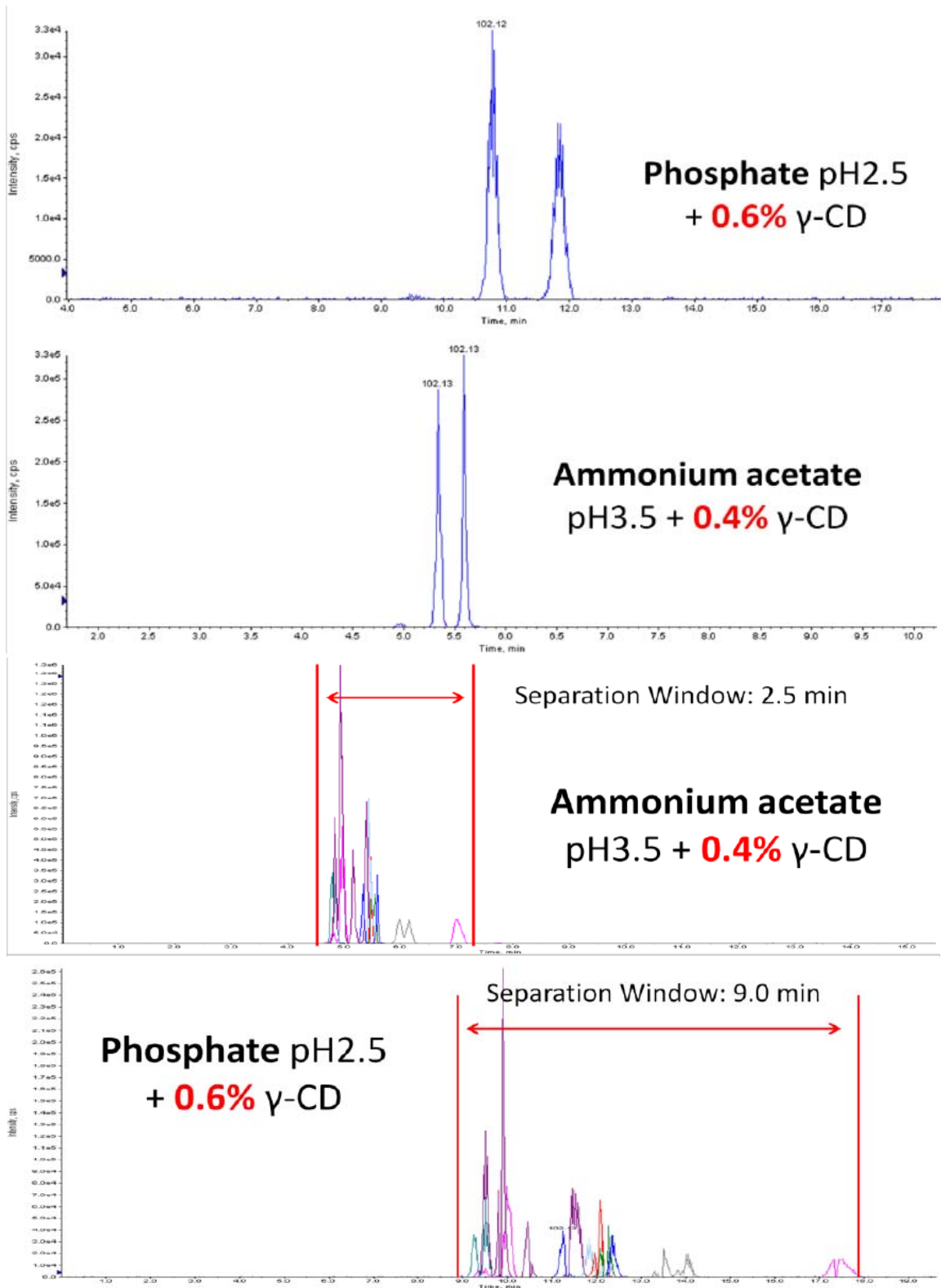

Figure 4.2 Buffer selection: ammonium acetate vs. phosphate.

The final two buffer candidates are phosphate and ammonium acetate. The comparison of these two buffers are shown as Figure 4.2. Two aspects are compared, first from the angle of peak shapes in electropherogram, which represents resolution and sensitivity. As shown in Figure 4.2, ammonium acetate demonstrates smooth peak shape. Secondly, the separation windows of the two buffers are compared. Phosphate buffer provides longer separation window, which can be treated as better separation ability in terms of selectivity.

Considering the chiral separation project is mainly focused on the separation, the author decided to choose the phosphate buffer because of its better separation ability.

Table 4.2 Effect of amount of HS- γ -CD filled in the capillary on peaks. Values are given as percentage in relation to the value for 70% (56 cm) partial filling

Amount of HS- γ -CD	Baseline Noise (%)	Sensitivity (%)
90% (72 cm)	139	75
80% (64 cm)	120	82
70% (56 cm)	100	100
60% (48 cm)	92	109
50% (40 cm)	87	115

4.3.1.2 Optimization of MS conditions

Once proper separation parameters were established, MS detection parameters were optimized for the cathinone analogs. Samples were directly infused into the mass spectrometer and scanned at different voltages in the positive electrospray ionization mode. To optimize ESI ionization, different voltages were applied to the ion optics. Among the mass spectrometry parameters tested were capillary voltages from 3000 to 4500 V, fragmentor voltages from 110 to 225 V, and skimmer voltages from 40 to 110V. The combination providing the best performance for compounds separated in the positive ion mode was 4000 V, 225 V and 50 V for the capillary, the fragmentor, and the skimmer respectively. Optimum conditions are demonstrated in Table 4.2.

Next, the CE and MS were connected together employing the optimum conditions described above. All of the compounds which could be separated in CE-UV mode were also separated and identified by CE-MS mode, though the elution order was different due to the change from neutral to charged cyclodextrins in the buffer. Since different cyclodextrins were employed in CE-UV and CE-MS, the separation results were expected to be slightly different. For instance, in the CE-MS experiments, Compound 1, 4-fluoromethcathinone and Compound 6, methedrone were enantiomerically separated by HS- γ -CD while in the CE-UV experiments using β -CD both compounds were eluted as a single peak. Similarly, certain compounds separated enantiomerically by β -CD were not fully separated by HS- γ -CD; for example, Compound 2 dimethylcathinone.

4.3.1.3 Partial-filling (PF) technique

The partial filling technique [145, 146] was employed in the CE-MS procedure to reduce contamination by the non volatile cyclodextrin assisted phosphate buffer. With partial filling, the HS- γ -CD buffer was aspirated into a fraction of the capillary instead of fully flushing the capillary. By doing so, the non-volatile portion of the buffer does not enter the mass spectrometer. To start with, the 80 cm capillary previously filled with phosphate buffer was filled with 50% (40 cm), 60% (48 cm), 70% (56 cm), 80% (64 cm) and 90% (72 cm) of its length with the phosphate buffer containing HS- γ -CD. Overall the 70% filling exhibited the best separation results and the lowest baseline noise. While the procedure reduces the overall separation efficiency in an amount proportional to the fill length, the baseline noise of the mass spectrometer is reduced by 45%.

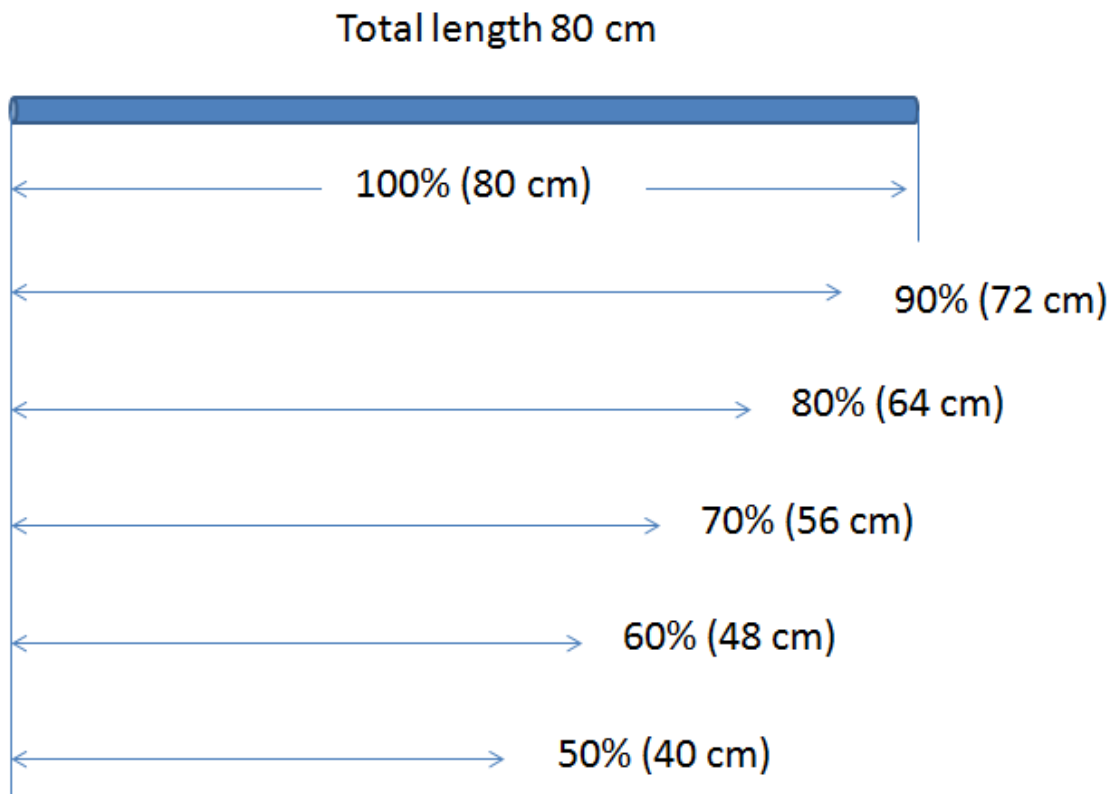

Figure 4.3 Different partial filling percentage (length of buffer filled in capillary divided by total length of capillary)

4.3.1.4 TOF-MS results

Figure 4.4 illustrates the extracted ion chromatogram of 12 cathinone analytes using the optimized CE-MS separation conditions. Compounds which have same molecular weight and thus the same mass to charge ratio, are extracted in the same pane. The twelve analytes are divided into eight groups with masses ranging from 178 to 276 Daltons. The number of each compound is the same as in UV experiment in Figure 3.7.

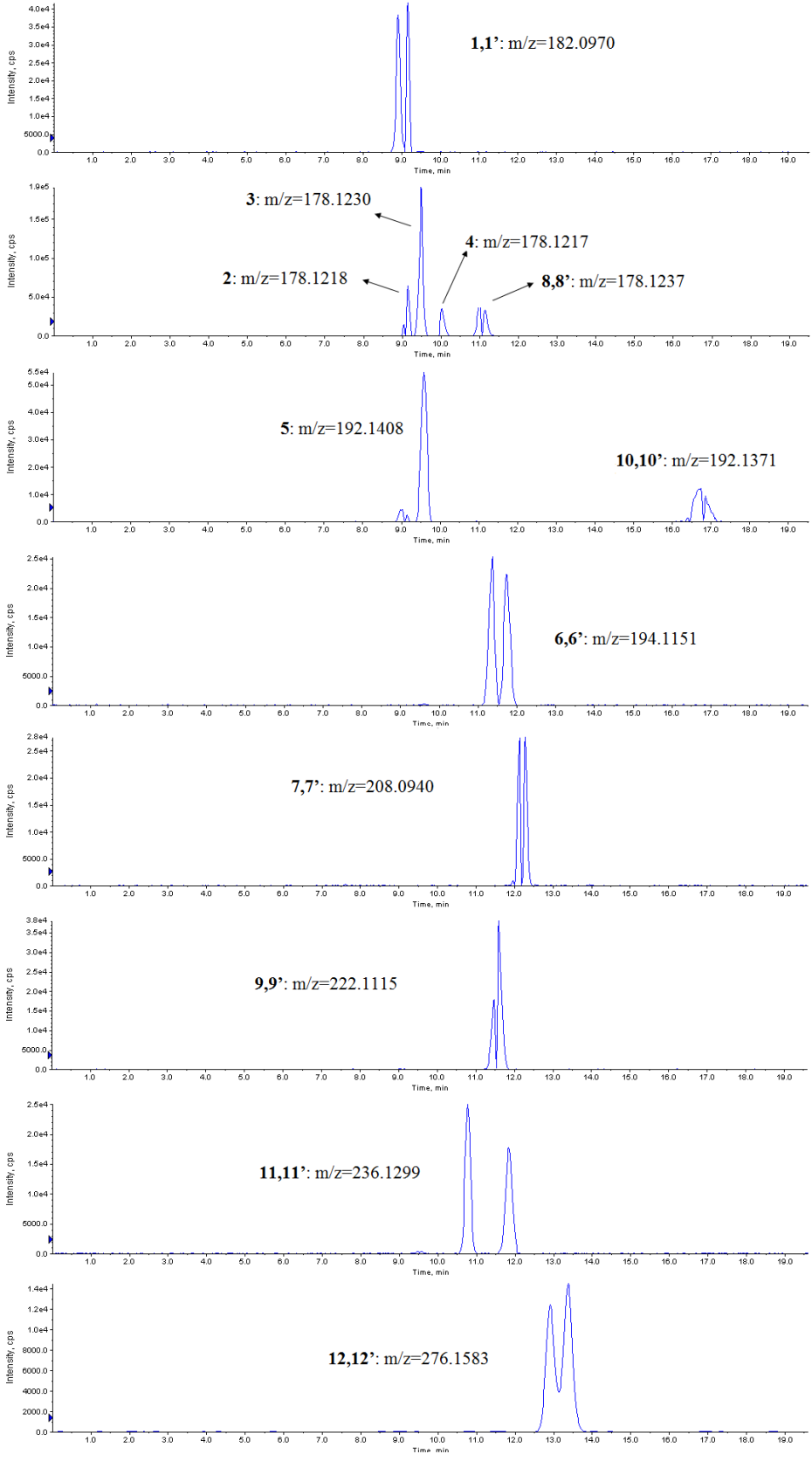

Figure 4.4 Extracted Ion Chromatograms at specific m/z of a mixture of 12 cathinone analytes at 0.5 µg/mL each using 50 mM pH 2.5 phosphate buffer with 0.6% (v/v) highly sulfated-γ-cyclodextrin, CE conditions: running voltage 25 kV, 5 kV for 10s injection, TOF-MS conditions: source temperature = 250 °C, drying gas = 5 mL/min, nebulizer pressure = 10 psig, positive ion mode (ESI+), capillary = 3000 V, fragmentor = 125 V, skimmer = 40 V. Peak identification: 4-Fluoromethcathinone (1,1'); Dimethylcathinone (2); Ethcathinone (3); Buphedrone (4); Pentedrone (5); Methedrone (6,6'); Methylone (7,7'); Mephedrone (8,8'); Ethylone (9,9'); 3,4-DMMC (10,10'); Pentylone (11,11'); MDPV (12,12'). The masses listed on the chromatogram are experimental values. See Table 4.3 for calculated values and mass errors.

Table 4.3 presents the exact mass measurements obtained by ESI-TOF-MS detection. The theoretical [M+H] values were calculated and compared with the experimental values. Mass errors in terms of Daltons and ppm are reported. The experimental values, relative standard deviations of the experimental values, and mass errors are calculated for experiments performed at 0.5 µg/mL using optimum separation conditions. n=5.

Table 4.4 demonstrates the linearity and sensitivity data for CE-MS results. Correlation coefficients, LODs and LOQs are calculated for all analytes, with 1.0 ng/mL to 11 ng/mL for LOD and 3 ng/mL to 33 ng/mL for LOQ. Comparing to the figures of merit for CE-UV, the MS detector provides lower LODs for 9 out of 12 analytes. Table 4 also illustrates the precision for the CE-MS procedure. Intra- and inter-day data were

analyzed and presented in the table. It should be noted that linearity could be further improved through the use of an internal standard [154].

Table 4.3 CE-ESI-TOF-MS accurate mass measurements for chiral analysis of cathinone analogs

Analyte	Formula	Ion Mode	m/z		m/z experimental	Error (Da)	Error (ppm)
			calculated [M + H]	experimental [M+H]			
Buphedrone	C11H15NO	+	178.1228	178.1217	2.8	-0.0011	-6.2
Penthedrone	C12H17NO	+	192.1384	192.1408	11	0.0024	-12.5
Methedrone	C11H15NO2	+	194.1177	194.1151	10	-0.0026	-13.4
Dimethylcathinone	C11H15NO	+	178.1228	178.1218	7.2	-0.0010	-5.7
Ethcathinone	C11H15NO	+	178.1228	178.1230	0.9	0.0002	1.1
4-Fluoromethcathinone	C10H12FNO	+	182.0978	182.0970	3.0	-0.0008	-4.4
3,4-DMMC	C12H17NO	+	192.1384	192.1371	2.5	-0.0013	-6.8
Ethylone	C12H15NO3	+	222.1126	222.1115	1.7	-0.0011	-5.0
Pentylone	C13H17NO3	+	236.1282	236.1299	3.7	0.0017	7.2
Mephedrone	C11H15NO	+	178.1228	178.1237	3.5	0.0009	5.0
MDPV	C16H21NO3	+	276.1594	276.1583	2.1	-0.0011	-4.0
Methylone	C11H13NO3	+	208.0970	208.0940	8.9	-0.0030	-14.4

Table 4.4 Figures of merit for the CE-ESI-TOF-MS results

Analytes	Linearity		Sensitivity		Precision	
	Slope	R ²	LOD (ng/mL)	LOQ (ng/mL)	(Intra-day, n=5) <i>t_m</i> (RSD%)	(Inter-day, 3d/n=6) <i>t_m</i> (RSD%)
4-Fluoromethcathinone	97.5	0.9900	1.2	3	0.87	0.96
Dimethylcathinone	38.2	0.9835	11	33	0.85	0.97
Ethcathinone	125.9	0.9920	1.0	3	0.96	0.97
Buphedrone	76.0	0.9736	3.5	10	0.97	0.99
Pentedrone	76.3	0.9521	3.7	11	0.95	0.99
Methedrone	78.9	0.9227	5.0	15	0.98	0.98
Methylone	15.7	0.9765	9.5	31	0.92	0.97
Mephedrone	82.9	0.9012	5.0	15	0.93	0.98
Ethylone	38.5	0.9638	3.8	11	0.99	0.98
3,4-DMMC	92.1	0.9967	5.0	15	0.99	0.98
Pentylone	68.1	0.9872	6.7	19	0.93	0.98
MDPV	77.0	0.9354	5.5	16	0.87	0.97

4.3.2 Analysis of seized drug samples

Bath salts are commonly used in various situations, both legally and illegally. In Florida, bath salts are a commonly used illicit drug of abuse [90, 157]. To examine the

capabilities of the previously mentioned procedure, eight previously analyzed seized drug samples were provided by Broward Sheriff's Office for analysis via CE-MS method and comparison with a previously validated GC-MS method. All of the tested samples contained methylone (m.w. 207.0892). One sample contained 3,4-Dimethylmethcathinone (3,4-DMMC, m.w. 191.1306) as well. Analyses of two of these samples are shown in Figure 4.5 and Figure 4.6.

The results of CE-MS match those obtained using of GC-MS from Broward Sheriff's Office, and also provide exact mass measurements to assist in the identification process. Methylone is currently a Schedule I controlled substance in State of Florida which is prohibited for use in medical treatments [158].

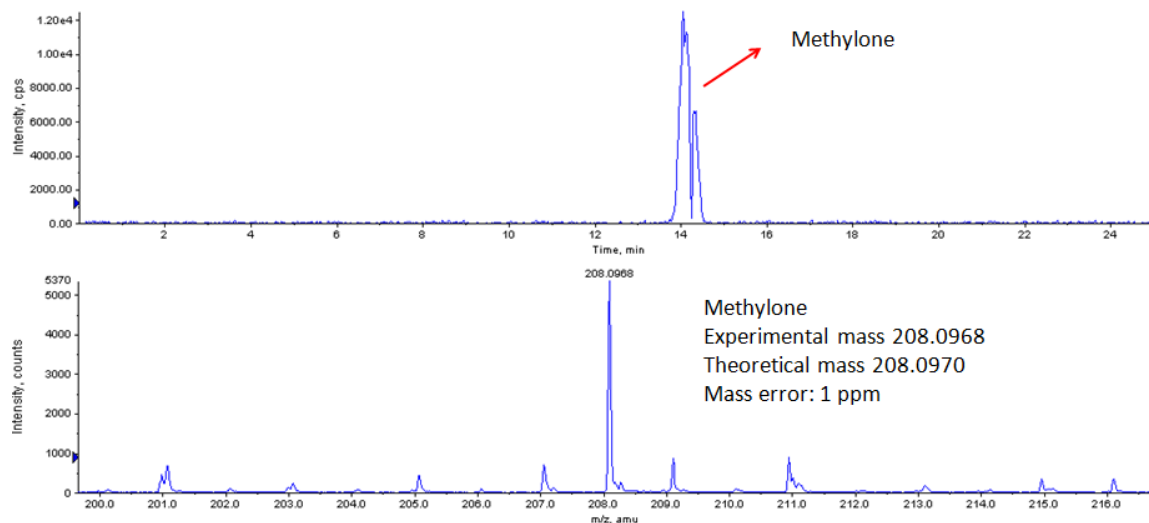

Figure 4.5 Sample A: TOF-MS Extracted Ion Chromatogram (top) and mass spectrum showing peak m/z 208.0968 (bottom).

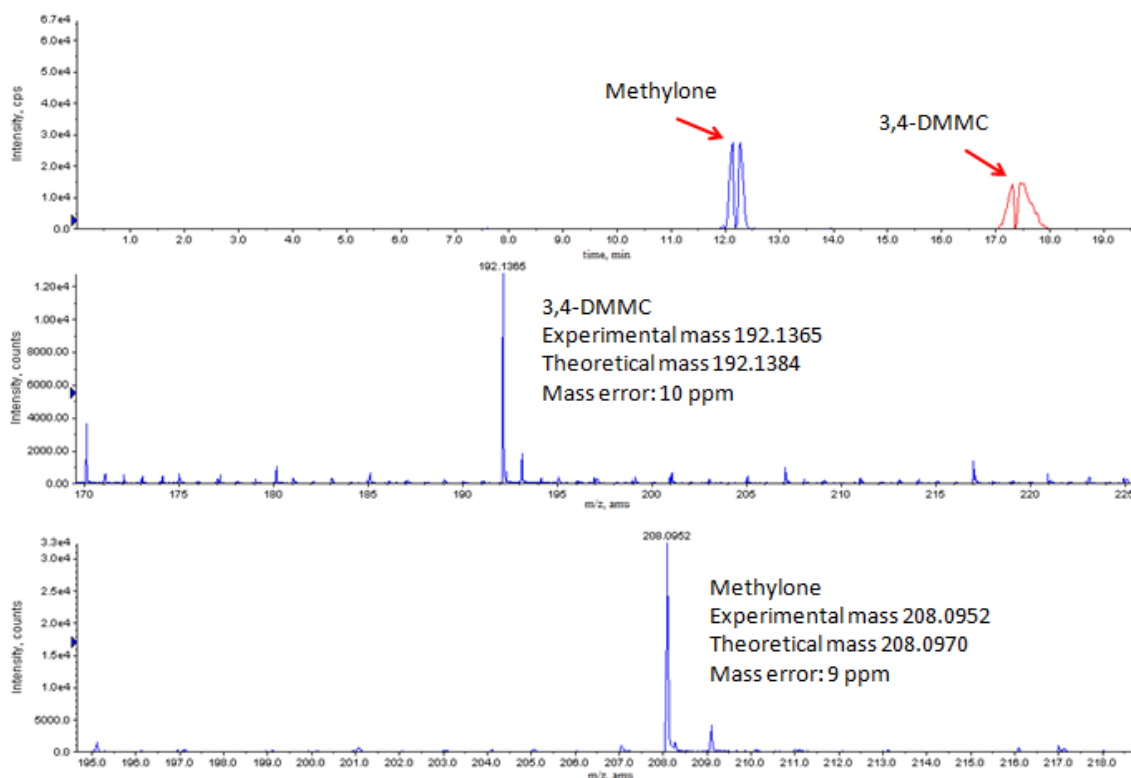

Figure 4.6 Sample B: TOF-MS Extracted Ion Chromatogram (top) and mass spectrum showing peaks m/z 192.1354 and m/z 208.0952 (bottom).

4.4 Concluding Remarks

This chapter demonstrates the development of an optimized method for the separation of 12 cathinone analogs using CE-TOF-MS. Experiments were performed in 50 μm I.D. uncoated fused silica capillaries with a total length of 80 cm. The running voltage was set to 25 kV. The procedure was adapted from utilizing β -cyclodextrin for CE-UV separation and optimized with highly sulfated γ -cyclodextrin for CE-MS detection. Initial attempts to use volatile buffers to improve the coupling of the MS to the CE system. However, the separation ability of volatile ammonium acetate and ammonium formate was not as good as the non-volatile phosphate buffer in terms of

selectivity. Thus, the use of the phosphate buffer was continued but the concentration was decreased from 100 mM in the CE-UV mode to 50 mM in the CE-MS mode. Meanwhile, HS- γ -CD was examined and employed instead of β -CD to avoid contamination of the mass spectrometer's ion source. Since HS- γ -CD is a negatively charged chiral selector, it was expected to migrate counter to the ion current which was set to be towards the anode. As a result, the potential for contamination of the MS ion source by non-volatile CD is greatly reduced. Lastly, a partial filling technique was used to further reduce the possibility of MS ion source contamination. Different percentages of partially filled capillaries were tested. A capillary with 70% full of phosphate buffer containing chiral selector was used to perform the experiment.

The method developed provides exact mass identification of individual analytes present in the mixture by TOF-MS. The procedure was tested using a small set of seized illicit bath salt samples obtained from law enforcement. The results of this study matched previously obtained data by GC/MS. Overall this method presents a useful procedure for separation and analysis of chiral cathinones. The low injection volume permitted by CE will make this method useful in forensic laboratories when a minimal sample input is required. Exact mass detection permits the determination of unknown compounds. To the author's knowledge, this is the first report of cathinone analogs separated and detected by both CE-UV and CE-TOF-MS.

CHAPTER 5 MICROCYSTIN AND CAPILLARY ELECTROPHORESIS MASS
SPECTROMETRY: AN ENVIRONMENTAL APPLICATION

5.1 Introduction

5.1.1 Cyanobacteria and microcystin

Cyanobacteria, also known as cyanophyta or blue green algae, are prokaryote photosynthetic organisms, which lack membrane-bound organelles and sexual reproduction [159-161]. The occurrence of cyanobacteria on the earth can be traced back for at least over 2.7 billion years. Cyanobacteria were the first organisms to have the ability to produce oxygen gas (O_2) as a by-product of photosynthesis [162], which is considered to have converted early atmosphere into an oxidizing one, leading to dramatic change in the composition of life forms on earth. Cyanobacteria can process photosynthetic nitrogen fixation by converting nitrogen (N_2) in the atmosphere into ammonium (NH_4), nitrites (NO_2^-) or nitrates (NO_3^-), which can be further converted into protein and nucleic acid for the simplest nutritional requirements of all living organisms [159]. Cyanobacteria also use the energy of sunlight to initiate photosynthesis for carbon fixation, the process which generally involves the conversion of inorganic carbon to organic compounds.

Cyanobacteria are widely distributed throughout the world, reflecting their genotypic and phenotypic variation [159]. They are commonly found in diverse types of every terrestrial habitat, including oceans, lakes, fresh water, deserts, and even in the extreme environment of Antarctica and thermal springs. The predominant habitats of

cyanobacteria are freshwater and marine environments, in which extensive and highly visible blooms can form. These harmful algae blooms are formed under favorable conditions, such as high temperatures, high pH, and intense light; they enhance the available nutrients released by anthropogenic activities [163, 164].

Certain cyanobacteria produce highly toxic secondary metabolites known as cyanotoxins, which are a severe threat to human and animal health as well as to the environment. Ingestion of water or food contaminated by cyanotoxins can lead to severe diseases such as acute gastro-intestinal disorder [164], inhalational problems, and death for humans and animals. Dermal exposure to the cyanotoxins also has the risk of acute skin irritant effects such as acute skin eruptions [165, 166]. Cyanobacteria can produce a range of cyanotoxins with structural diversity and biological activity differences, such as microcystins, cylindrospermopsins, saxtoxins, and domoic acid (Figure 5.1).

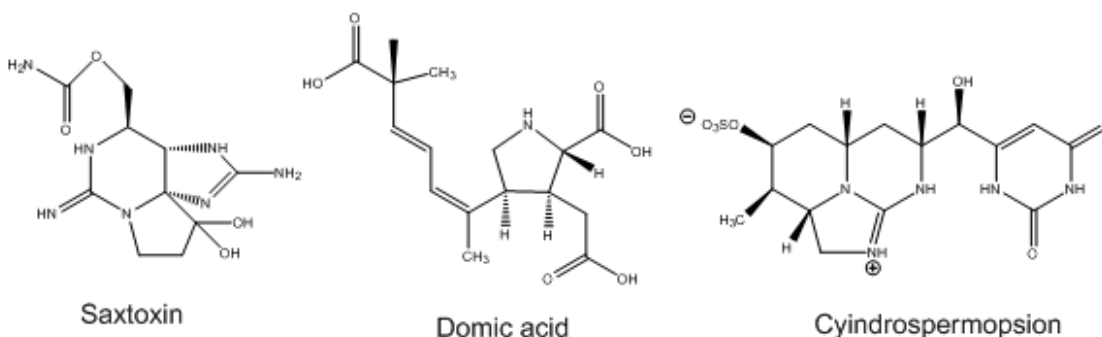

Figure 5.1 Structures of some cyanobacteria

One of the most problematic cyanotoxins is microcystin, a cyclic peptide toxin with seven amino acids and a cyclo (D-Glu-MDHA-D-Ala-L-Leu-D-Asp-l-Arg). Microcystin contains a unique non-protein amino acid, 3-amino-9-methoxy-2,6,8-trimethyl-10-phenyldeca-4,6-dienoic acid, also known as ADDA [166], which is critical for biological activity. Microcystin is also considered to be a hepatotoxin and is produced by various genera of freshwater cyanobacteria, such as microcystis, anabaena, nostoc, and oscillatoria [167, 168]. The general mechanisms of hepatotoxin are related to the inhibition of protein synthesis [169]. For example, hepatotoxins can inhibit protein phosphatase enzymes (PP1 and PP2A) within liver cells, resulting in increased liver weight and modified plasma membranes [169]. Hepatotoxins can also cause damage of liver structure by hypovolemic shock and extra accumulation of blood in the liver [170].

Microcystins impact aquatic ecosystems, especially aquatic invertebrates. Rohrlack *et al.* [171] studied the effects of ingestion of microcystins on *Daphnia galeata* and found that ingestion of the microcystin-producing PCC 7806 wild type cells leads to lethal poisoning. Chen *et al.* [172] also reported the effects of microcystin on *Daphnia galeata* and demonstrated that high concentrations and longtime exposure to microcystin were fatal, leading to the accumulation and inhibition of the enzyme phosphatase. Microcystin was also reported to be harmful to fish. Exposure to microcystin during feeding or breathing can lead fish to die. The paper published by Tencalla [173] indicated that microcystin transferring route in trout is via the gastrointestinal tract, and that toxicity is manifested as massive hepatic necrosis.

Human exposure to microcystin generally occurs through ingestion of microcystin contaminated water or food, or through a dermal route during recreational activities when harmful algae blooms. Besides the affected organs in the liver, other affected organs such as kidneys and colon cause illness as gastroenteritis, irradiant and allergic skin effects, and liver diseases. Human exposure to low but long-term concentrations of microcystin can cause chronic diseases, such as tumors and cancers, which are related to the toxicity of microcystin. Therefore, the World Health Organization (WHO) established a maximum value of 1 ppb for microcystin-LR in drinking water in 1997 [169, 174].

The first notable incident of microcystin toxicity on human health was discovered in the town of Caruaru in Brazil in 1996, which led to 76 deaths from liver complications due to intake of contaminated water. The symptoms of these patients were headache, eye pain, blurred vision, nausea, and vomiting. Further analysis and determination found the existence of microcystin in blood and liver of patients [175]. Other cases involving human poisoning by microcystin toxicity have also been reported. In England, two canoeing exercisers drank microcystin contaminated water, which lead to left basal pneumonia for four to five years [176]. Another accident occurred in Brazil where the poisoning resulted from the blooms of anabaena and microcystin freshwater genera. This poisoning incident led to gastroenteritis in 2,000 people and 88 deaths over a period of 42 days [169].

5.1.2 Current analytical approaches for microcystin detection

Many scientific studies have been published for separation and identification of various microcystin family compounds using different analytical instrumentation and

methods, including HPLC / HPLC-MS [177-180], GC / GC-MS [181-183], and TLC [184-186]. However, these methods suffer from either tedious sample pretreatment procedures or low sensitivity. Capillary electrophoresis has been widely used for separation and detection of microcystin variables because of its simplicity, low sample volume requirement, and high sensitivity [180, 187-190].

Gabor Vasas *et al.* [191] reported separation of three cyanotoxin compounds (ANA-a, MCY-LR, and CYN). Both CZE and MEKC methods were examined and different parameters were tested. The authors presented optimum separation conditions with borate buffer at high pH conditions for CZE and sodium tetraborate containing SDS for MEKC. All three compounds were separated within 4 min in the CZE mode. However, buffers containing SDS are not suitable for coupling CE with the MS detector, as the nonvolatile detergent may contaminate the MS ion source.

E.C. Aguete *et al.* [192] demonstrated a procedure for separating three cyanotoxin analytes (RR, LR, and YR) by HPLC and HPCE. Samples were pretreated using immunoaffinity extraction. All three compounds were separated within 20 min in both the HPLC and HPCE modes.

The goal of this project is to develop a method which allows rapid separation and detection of various microcystin compounds with CE separation with coupling to both the UV/Vis and MS detectors. To the author's knowledge, this is the first report where the three microcystins MC-RR, MC-YR, and MC-LR have been separated within 6 min using both CE-UV and CE MS techniques.

5.2 Experimental

5.2.1 Chemicals and materials

Phosphoric acid and acetic acid were purchased from Fisher Scientific (Pittsburgh, PA, USA); ammonium acetate, ammonium dihydrogen phosphate, ammonium formate, sodium phosphate monobasic monohydrate, and sodium hydroxide from Sigma-Aldrich (St. Louis, MO, USA); β -cyclodextrin from TCI America (Portland, OR, USA); highly sulfated γ -cyclodextrin from Beckman Coulter (Brea, CA, USA); and sodium phosphate dibasic heptahydrate from Acros Organics (Morris Plains, NJ, USA).

Acetonitrile (ACN), methanol (MeOH), isopropanol, and phosphoric acid used for the preparation of the buffer electrolytes, were of analytical reagent grade (Carlo Erba, Milan, Italy). Distilled water was deionized by a Milli-Q water purification system (Millipore, Bedford, MA, USA).

5.2.2 Instrumentation

The separation of cathinone standards and commercial samples was performed using a fully automated CE system (G1600, Agilent Technologies, Santa Clara, CA, USA) with the column temperature maintained at 25 °C. Separations were performed in 50 μ m ID uncoated fused silica capillaries with a total length of 50 cm. The capillary columns were obtained from Polymicro (Phoenix, AZ, USA). Each new capillary was rinsed with 1.0 M NaOH for 10 min and water for 5 min. Samples were introduced into the capillary using electrokinetic injection for 15s at 10 kV. CE-UV detection was performed via on-column measurements using a diode array detector (DAD) at a wavelength of 206 nm.

The time of flight mass spectrometry (TOF-MS) analysis was performed in the positive ion mode using partial filling technique [36-39] to minimize contamination of the MS with non-volatile cyclodextrins. The CE system was connected to a TOF-MS, (3250a MSD, Agilent Technologies, Santa Clara, CA, USA) with a CE-ESI-MS sprayer interface. Reference masses obtained from Agilent (G1969-85001 API-TOF reference mass solution kit), including purine at 121.0509 m/z and HP0921 at 922.0098 m/z, were added to the sheath flow liquid to calibrate the mass spectrometer. The sheath flow – which was composed of 50:50 (v/v) deionized water and methanol along with reference mass solutions – was provided by an isocratic pump set to a low flow rate of 0.5 mL/min with a 1:100 split ratio, resulting in a net flow rate of 0.005 mL/min.

5.3 Results and Discussion

Detailed methodology of the project was presented in the thesis titled “Quantitative analysis and determination of microcystin in water by capillary electrophoresis mass spectrometry” by Bingxue Zheng in 2014 [193]. In short, four microcystin variables were separated within 6 min by phosphate buffer containing β -cyclodextrin. Different separation conditions, such as pH, buffer ionic strength, and various organic modifiers were tested in the thesis of Zheng, B.. However, due to lack of confirmatory information provided by UV/Vis spectrometry, it is necessary to introduce another confirmatory method to identify the analytes. MS was widely used coupled with HPLC or CE for microcystin analysis [194-197].

In this chapter, the CE-MS portion of the project will be mainly discussed.

5.3.1 Volatile buffer consideration for MS detection

When extending the capillary to the MS detector, the main consideration is how to avoid MS ion source contamination. The 100 mM phosphate buffer was utilized in the CE-UV part of the analysis; however, it was not advisable to continue using the same buffer, as 100 mM is too high a concentration for MS detector, and phosphate is a non-volatile buffer. However, a number of studies [150, 151] have indicated that with the introduction of the sheath liquid, the concentration of the phosphate buffer could be further diluted to 1:100 ratio. Because of this consideration, phosphate buffer was employed; however, 50 mM buffer was prepared instead of 100 mM. Volatile buffers, such as ammonium acetate and ammonium formate, were also tested. However, their separation performance was not as good as with phosphate buffer.

5.3.2 TOF-MS results

Figure 5.2 represents the extracted ion chromatogram of three microcystin variables. As the figure shows, all three compounds were separated by 50 μ m ID capillary and identified by TOF-MS within 6 min. Since TOF is an accurate mass analyzer, the molecular mass info was obtained to four decimal places, which is a powerful tool to accurately identify the analytes.

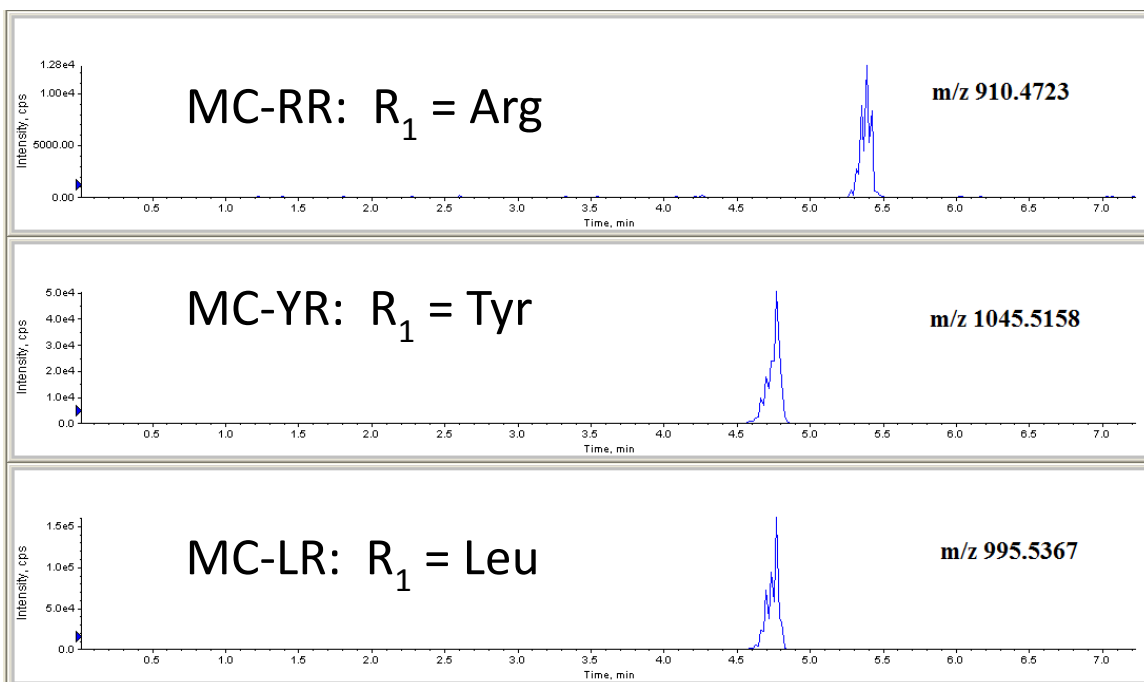

Figure 5.2 Extracted mass spectrum of MC-RR, MC-YR and MC-LR.

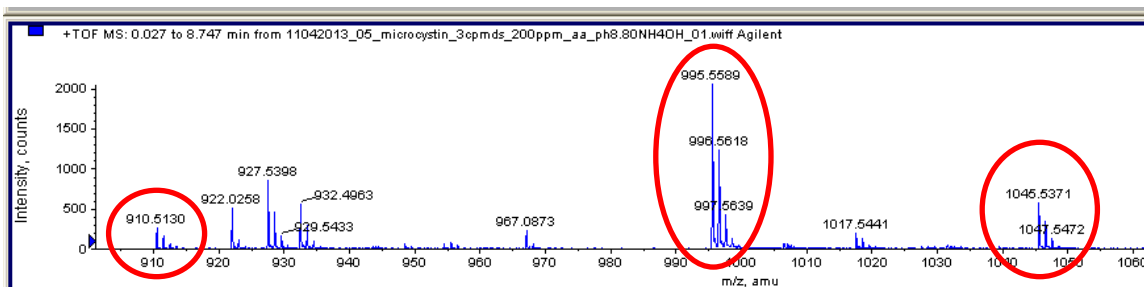

Figure 5.3 Mass spectrum of MC-RR, MC-YR and MC-LR.

Mass measurements are presented in Table 5.1. As shown in the table, low error in terms of amu and ppm was achieved with the TOF-MS system. It can be proved that TOF-MS is an accurate measurement method for analyte identification.

Table 5.1 Accurate mass measurements of the three microcystin analytes

Compound	Formula	M (calculate)	M+H (calculated)	M+H (experimental)	Error (amu)	Error (ppm)
MC-LR	C ₄₉ H ₇₄ N ₁₀ O ₁₂	994.5470	995.5548	995.5589	0.0041	4
MC-YR	C ₅₂ H ₇₂ N ₁₀ O ₁₃	1044.5263	1045.5341	1045.5371	0.0030	3
MC-LA	C ₄₆ H ₆₇ N ₇ O ₁₂	909.4831	910.4909	910.5130	0.0221	24

5.4 Concluding Remarks

This chapter presents a rapid and novel procedure for separation and identification of microcystin variables using capillary electrophoresis with mass spectrometry as a detection method. A 50 μm I.D. uncoated fused silica capillary with a total length of 70 cm was used for the CE-MS experiments. Experiments were carried out using 25 kV as the running voltage. Phosphate buffer was used for the separation. Different pH, buffer concentrations, and various amounts of organic modifiers and chiral selectors were examined. The optimum separation results were achieved with 100 mM phosphate buffer at pH 8.0 with 10 mM β -CD adding to the buffer for the CE-UV part. For the CE-MS part, a 50 mM phosphate buffer at pH 7.5 without β -CD was utilized for optimum separation. All three microcystin analogs were separated within 6 min. Accurate molecular weight was obtained through TOF-MS, and mass errors were calculated. The method was applied to spiked microcystin samples and real environmental samples (pond water).

CHAPTER 6 OVERALL CONCLUSIONS

This dissertation demonstrates several novel and advanced capillary electrophoretic techniques for forensic, pharmaceutical, and environmental applications. The idea of the overall work is to utilize the advantages of capillary electrophoresis coupling with mass spectrometric techniques over other hyphenated chromatographic techniques, i.e. gas chromatography mass spectrometry and liquid chromatography mass spectrometry. In order to accomplish my goals of separation and detection of chiral, neutral, and charged molecules by mass spectrometry, different procedures of capillary electrophoretic techniques – including monolithic capillary electrochromatography, capillary zone electrophoresis, and partial filling technique – were explored, examined and discussed in this dissertation.

Chapter 1 introduces the background of the overall project, challenges, and problems existing in forensic, pharmaceutical, and environmental applications as well as general principles of capillary electrophoresis systems.

Chapter 2 exhibits the principles of capillary electrochromatography and a novel development of monolithic CEC columns. Hexyl acrylate based monolithic columns were developed and optimized. A porous structure was built inside of 100 μm I.D. transparent capillary columns. Monomer solutions were prepared using different organic chemicals as described in the chapter and polymerized with UV lamp under 360 nm radiations. Various approaches were made to ensure the quality of the home-made capillary columns. This chapter details a method for separation and identification of six antidepressant compounds using an acrylate-based porous monolith capillary. Capillary

electrochromatography coupled with the UV detector was explored. The CEC-UV method provides an effective and efficient method for the separation and identification of the analytes. Spiked urine samples were utilized to check the capability of the method. A liquid-liquid extraction procedure was established to perform sample extraction. Time-of-flight mass spectrometry was also employed for spiked urine sample analysis, and accurate molecular information was obtained.

Chapter 3 explores an approach to fulfill enantioseparation of chiral compounds with adding cyclodextrin to the background electrolyte. Compared to HPLC, GC, or CEC methods, this method provided a simplified way to accomplish the chiral separation. In this chapter, a rapid chiral separation of 12 cathinone analogs has been developed and validated using cyclodextrin-assisted CE with UV and time of flight mass spectrometric (TOF-MS) detection. Optimum separation was obtained on a 57.5 cm \times 50 μ m capillary using a buffer system consisting of 10 mM β -cyclodextrin (β -CD) in a 100mM phosphate buffer for CE-UV. All analytes were separated within 18 minutes in the CE-UV mode. Ten compounds were enantiomerically separated using β -cyclodextrin. Detection limits down to 1.0 ng/mL were obtained. The method was then validated by analytical performing tests including LOD, LOQ, and RSD%.

Chapter 4 demonstrates a CE-MS method of enantioseparation on the basis of CE-UV procedures described in Chapter 3. In this study, time of flight mass spectrometric (TOF-MS) detection was employed to identify accurate mass information of 12 cathinone analytes. Time-of-flight mass spectrometry is a more accurate measurement than UV, because it can confirm the presence of a certain compound in the samples. Optimum

separation was obtained on a 80 cm × 50 μm capillary using a buffer system consisting of 0.6% (v/v) highly sulfated-γ-cyclodextrin (HS-γ-CD) in a 50 mM phosphate buffer. In the CE-MS experiments, a partial filling technique was employed to ensure that a minimum amount of cyclodextrin entered the mass spectrometer in order to avoid contamination of the MS ion source. All analytes were separated within 18 minutes and identified by TOF-MS. The CE-MS method was then applied to examine the seized drugs.

Chapter 5 discusses the applications of capillary electrophoresis mass spectrometry in environmental toxicology using microcystin as an example. Microcystin belongs to cyanotoxin and has several different varieties. In this chapter, a rapid separation and identification method of four microcystin compounds was developed with a 50 μm ID capillary using a phosphate buffer as the background electrolyte. Compared to previous published methods, the procedure demonstrated in this chapter achieved fast separation within 6 min. In addition, accurate molecular information on each analyte was acquired with TOF-MS detection.

CHAPTER 7 FUTURE RESEARCH ON FORENSIC, ENVIRONMENTAL AND PHARMACEUTICAL APPLICATIONS BY ADVANCED CAPILLARY ELECTROPHORESIS TECHNIQUES

Though capillary zone electrophoresis is a fairly simple form of electrophoretic technique, the increasing demand for achieving impressive separation efficiency makes scientists continue to optimize current approaches and explore new methods. In this chapter, I consider several ideas that could be of potential interest for research, which are presented below.

7.1 Monolithic Chiral Stationary Phases

Currently, the hexyl acrylate based monolithic column has been successfully applied for separation of neutral and charged small molecules as detailed in Chapter 2. As demonstrated in that chapter, monolithic CEC techniques can provide improved separation ability for neutral and charged small molecules. Future study can be conducted with further modification to the monolithic stationary phase in order to achieve the goal of chiral separation. Several monolithic chiral stationary phases have been developed for CEC. It is very important to focus on these chiral selectors, as many of the drugs and metabolites are chiral compounds which possess quite different pharmacodynamic characteristics [198]. Recent achievements using chiral stationary phases with CEC have been described in several review articles [82, 83, 199]. In order to prepare a chiral stationary phase, one approach is binding the most commonly used chiral selector

cyclodextrin to the silica wall of the capillary column. The proposed method is shown as Figure 7.1 [200-202].

The reaction starts with regular β -CD reacting with $\text{CH}_2\text{CH}(\text{CH}_2)_n\text{Br}$ in sodium hydroxide and DMSO condition. The $\text{CH}_2\text{CH}(\text{CH}_2)_n$ group is added to one of OH group on the ring of CD. The intermediate product continues reacting with $\text{CH}_3\text{I} / \text{NaH}$ and dimethylsiloxane. The final product is synthesized.

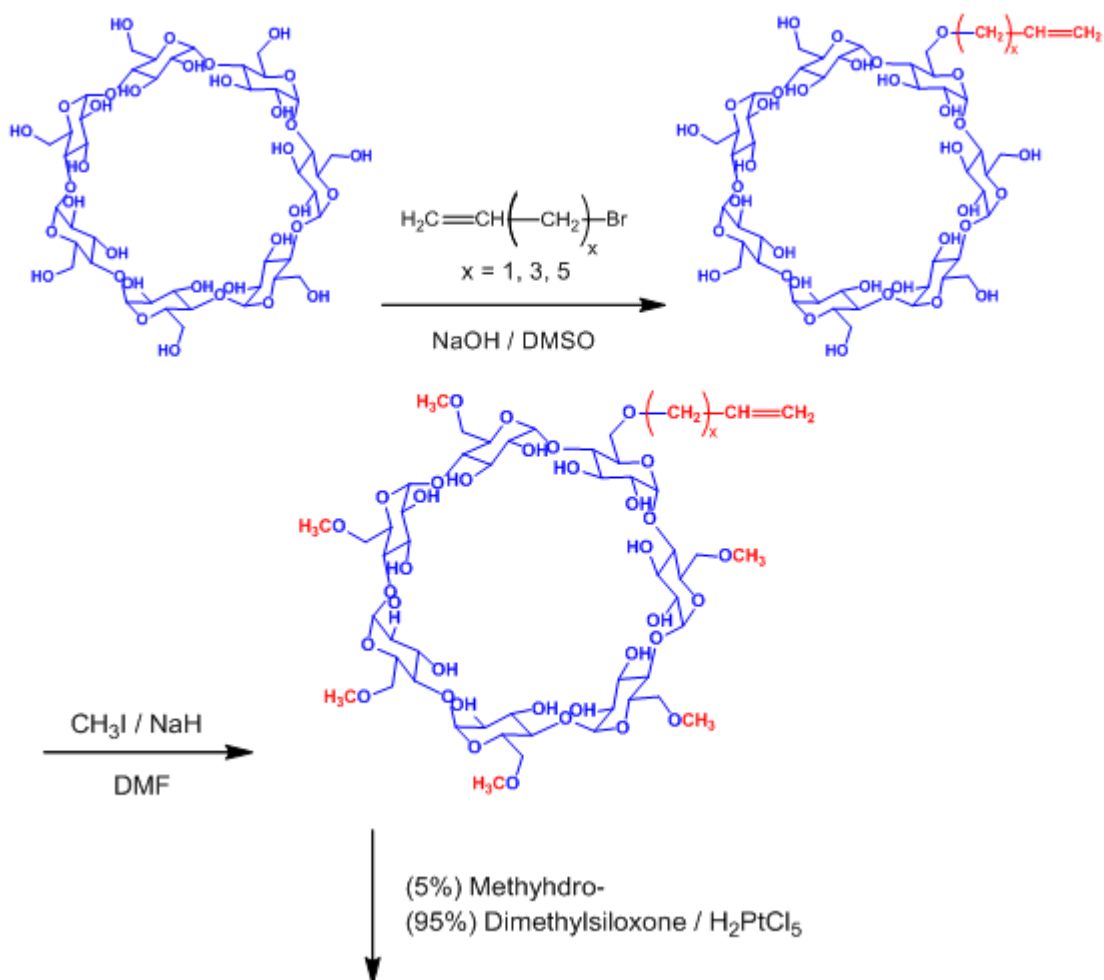

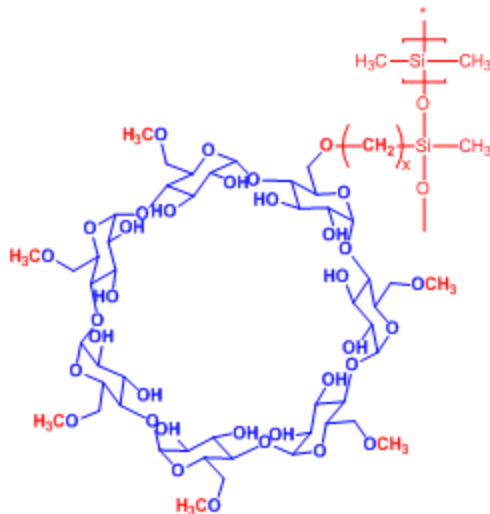

Figure 7.1 Synthesis of chemically modified chiral polysiloxanes Chirasil-Dex. DMSO = dimethyl sulfoxide, DMF = dimethylformamide, polysiloxane = methylhydro/dimethylpolysiloxane 5/95. Adapted from Ref. [200].

7.2 Monolithic CEC Microchips

In recent years, miniaturization has become an important topic across different scientific disciplines in the scientific world. The two main advantages of miniaturized devices currently attracting the attention of scientists are portability and low cost of fabrication. Different research groups have been working on miniaturization of different devices, including microfluidic chips, mass spectrometry, and others [203-205]. I am interested on miniaturization of capillary electrophoresis systems, which is commonly referred to as microfluidic chips [203, 206], or micro total analysis systems (μ TAS), for further research.

Since the hexyl acrylate based monolithic capillary columns were fabricated, the potential exists to introduce the monomer mixture into the small channel of the microchip

plate, polymerize the mixture, and shape it to the desired structure inside the microchip channel.

At the moment, there are two ways of in situ polymerization for preparing a continuous monolithic bed, chemical initiation [207, 208] and photoinitiation [203, 209-212]. The polymerization method presented in Chapter 2 utilized photoinitiation by a 360 nm UV box. In addition, mass spectrometry detection was even coupled with monolithic CEC microchips for a protein digest analysis [210].

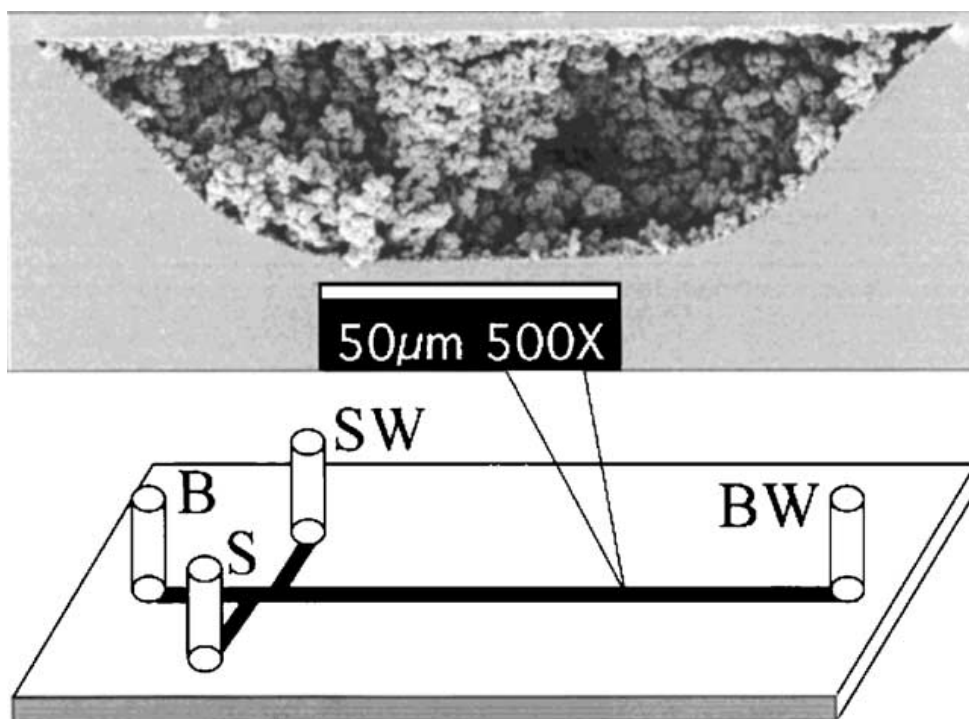

Figure 7.2 A polymer-based monolithic CEC microchip was fabricated by Daniel J. Throckmorton, Timothy J. Shepodd, and Anup K. Singh. The structure was photoinitiated using acrylate based monomer mixture. Adapted with permission from Ref. [203]. Copyright (2002) American Chemical Society.

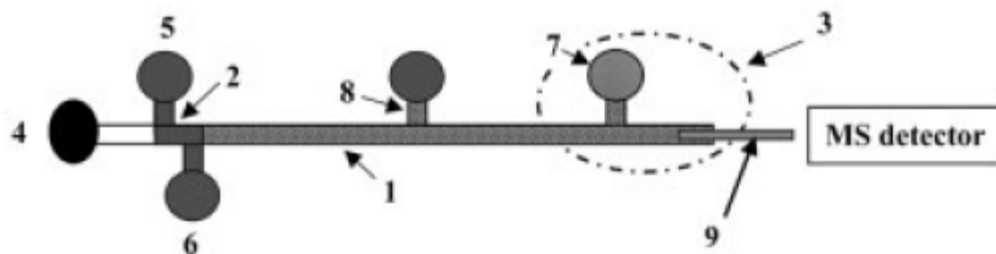

Figure 7.3 Schematic diagram of the microchip CEC-MS configuration: (1) separation channel; (2) double-T injector; (3) ESI source; (4) eluent reservoir; (5) sample inlet reservoir; (6) sample waste reservoir; (7) eluent waste reservoir that houses the porous glass gate; (8) side channel for flushing the monolithic channel; (9) ESI emitter. Adapted with permission from Ref. [210]. Copyright (2003) WILEY-VCH.

7.3 Capillary Zone Electrophoresis for Chiral Separation

As detailed in Chapter 4 and 5, simultaneous enantioseparation of 12 cathinone analogs was successfully achieved by β -CD and HS- γ -CD. It is possible to use other chiral selectors as alternative ways to fulfill the goal of enantioseparation using CE with UV and MS detection. Several chiral selectors have been reported for chiral separations, including antibiotics [128, 132, 213, 214], crown ether [121, 124, 126, 215, 216], and other compounds [217, 218]. However, it should be noted that among various chiral selectors, CD and its derivatives are the most widely used chiral selectors by far because of their low UV absorption in 190 – 400 nm band and because of their widespread commercial availability. I would like to continue the research by choosing volatile chiral selectors, which are MS-friendly.

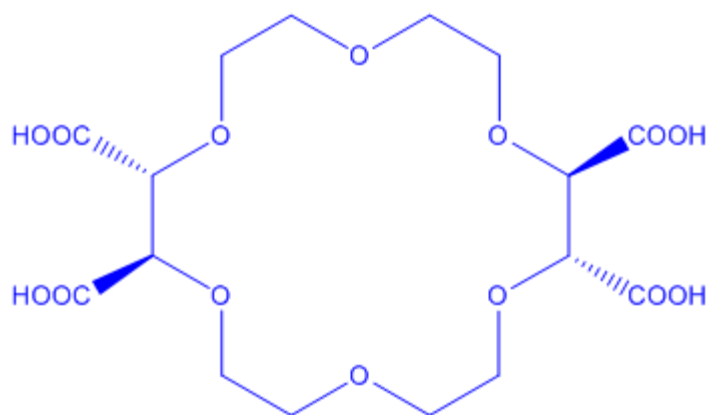

Figure 7.4 Chemical structure of 18C6H4.

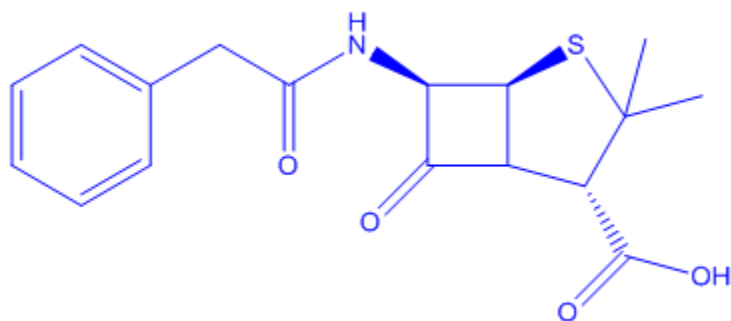

Figure 7.5 Chemical structure of penicillin G potassium salt (PenG) used as chiral selector in Ref. [116].

"An education isn't how much you have committed to memory, or even how much you know. It's being able to differentiate between what you do know and what you don't."

Anatole France, French author, 1844–1924.

-END-

LIST OF REFERENCES

- [1] Lodge, A., Master's Thesis *Electrophoresis*. 1886.
- [2] Li, S. F. Y., *Capillary Electrophoresis: Principles, Practice, and Applications*, Elsevier Science, the Netherlands 1992.
- [3] Smirnow, I., *Berl. Klin. Wochenschr.* 1892, 32, 645.
- [4] Hardy, W. B., *J. Physiol.* 1899, 24, 288.
- [5] Hardy, W. B., *J. Physiol.* 1905, 33, 273.
- [6] Field, C. W., Teague, O., *J. Exp. Med.* 1907, 9, 86.
- [7] Tiselius, A., *Transactions of the Faraday Society* 1937, 33, 524-531.
- [8] Nobelprize.org, Nobel Media AB 2013.
- [9] Tiselius, A., Svensson, H., *Transactions of the Faraday Society* 1940, 35, 16-22.
- [10] Tiselius, A., *Discussions of the Faraday Society* 1949, 7, 7-11.
- [11] Shepard, C. C., Tiselius, A., *Discussions of the Faraday Society* 1949, 7, 275-285.
- [12] Tiselius, A., *Discussions of the Faraday Society* 1953, 13, 29-33.
- [13] Tiselius, A., *Journal of the Chemical Society (Resumed)* 1954, 2650-2657.
- [14] Hjertén, S., *Chromatogr. Rev.* 1967, 9, 122.
- [15] Jorgenson, J. W., Lukacs, K. D., *Journal of Chromatography A* 1981, 218, 209-216.
- [16] Jorgenson, J., Lukacs, K., *Science* 1983, 222, 266-272.
- [17] Jorgenson, J. W., Lukacs, K. D., *Clinical Chemistry* 1981, 27, 1551-1553.
- [18] Lukacs, K. D., Jorgenson, J. W., *Journal of High Resolution Chromatography* 1985, 8, 407-411.
- [19] Terabe, S., Otsuka, K., Ichikawa, K., Tsuchiya, A., Ando, T., *Analytical Chemistry* 1984, 56, 111-113.
- [20] Hjertén, S., Pan, H., *Biochimica et Biophysica Acta (BBA) - Biomembranes* 1983, 728, 281-288.

- [21] Hjertén, S., *Journal of Chromatography A* 1985, 347, 191-198.
- [22] Hjertén, S., Zhu, M.-d., *Journal of Chromatography A* 1985, 346, 265-270.
- [23] Ericson, C., Liao, J.-L., Nakazato, K. i., Hjertén, S., *Journal of Chromatography A* 1997, 767, 33-41.
- [24] Shamsi, S. A., *Analytical Chemistry* 2001, 73, 5103-5108.
- [25] Deyl, Z., Švec, F., *Capillary Electrochromatography*, Elsevier Science, 2001.
- [26] Anastos, N., Barnett, N. W., Lewis, S. W., *Talanta* 2005, 67, 269-279.
- [27] Landers, J. P., *Handbook of capillary and microchip electrophoresis and associated microtechniques*, CRC Press 2008.
- [28] Baker, D. R., *Capillary electrophoresis*, Wiley, New York 1995.
- [29] Felhofer, J. L., Chumbimuni-Torres, K. Y., Mora, M. F., Haby, G. G., García, C. D., *Capillary Electrophoresis and Microchip Capillary Electrophoresis*, John Wiley & Sons, Inc. 2013, pp. 1-22.
- [30] United Nations Office on Drugs and Crime (UNODC), the World Drug Report, 2013.
- [31] United Nations Environment Programme (UNEP), the Annual Report, 2012.
- [32] Greenpeace, the Annual Report, 2012.
- [33] Ali, I., Aboul-Enein, H. Y., *Chiral Pollutants: Distribution, Toxicity and Analysis by Chromatography and Capillary Electrophoresis*, John Wiley & Sons, Ltd 2004, pp. 1-35.
- [34] Saito, Y., Kawazoe, M., Hayashida, M., Jinno, K., *Analyst* 2000, 125, 807-809.
- [35] Frahnert, C., Rao, M. L., Grasmäder, K., *Journal of Chromatography B* 2003, 794, 35-47.
- [36] Duverneuil, C., de la Grandmaison, G. L., de Mazancourt, P., Alvarez, J.-C., *Therapeutic Drug Monitoring* 2003, 25, 565-573.
- [37] Sauvage, F. L., Gaulier, J. M., Lachâtre, G., Marquet, P., *Therapeutic Drug Monitoring* 2006, 28, 123-130.
- [38] Lajeunesse, A., Gagnon, C., Sauvé, S., *Analytical Chemistry* 2008, 80, 5325-5333.
- [39] Sørensen, L. K., *Journal of Chromatography B* 2011, 879, 727-736.

- [40] Rosenbaum, C., Carreiro, S., Babu, K., *J. Med. Toxicol.* 2012, 8, 15-32.
- [41] Cadel-Six, S., Moyenga, D., Magny, S., Trotureau, S., Edery, M., Krys, S., *Environmental Pollution* 2014, 185, 333-339.
- [42] Peters, F. T., Schaefer, S., Staack, R. F., Kraemer, T., Maurer, H. H., *Journal of Mass Spectrometry* 2003, 38, 659-676.
- [43] Rodríguez, I., Quintana, J. B., Carpinteiro, J., Carro, A. M., Lorenzo, R. A., Cela, R., *Journal of Chromatography A* 2003, 985, 265-274.
- [44] Meyer, M., Wilhelm, J., Peters, F., Maurer, H., *Anal Bioanal Chem* 2010, 397, 1225-1233.
- [45] Langel, K., Gunnar, T., Ariniemi, K., Rajamäki, O., Lillsunde, P., *Journal of Chromatography B* 2011, 879, 859-870.
- [46] Xu, X., Yu, R., Wang, L.-p., Wu, S., Song, Q., *Analytical Methods* 2013, 5, 1799-1805.
- [47] Ríos, V., Prieto, A. I., Cameán, A. M., González-Vila, F. J., de la Rosa, J. M., Vasconcelos, V., González-Pérez, J. A., *Chemosphere*.
- [48] Gahm, K. H., Huang, K., Barnhart, W. W., Goetzinger, W., *Chirality* 2011, 23, E65-E73.
- [49] Ren-Qi, W., Teng-Teng, O., Siu-Choon, N., Weihua, T., *TrAC Trends in Analytical Chemistry* 2012, 37, 83-100.
- [50] Toribio, L., Bernal, J. L., Martín, M. T., Bernal, J., del Nozal, M. J., *Biomedical Chromatography* 2014, 28, 152-158.
- [51] Płotka, J. M., Biziuk, M., Morrison, C., Namieśnik, J., *TrAC Trends in Analytical Chemistry* 2014, 56, 74-89.
- [52] Howlett, S. E., Steiner, R. R., *Journal of Forensic Sciences* 2011, 56, 1261-1267.
- [53] Ferenczi-Fodor, K., Végh, Z., Renger, B., *Journal of Chromatography A* 2011, 1218, 2722-2731.
- [54] Cheng, S.-C., Huang, M.-Z., Shiea, J., *Journal of Chromatography A* 2011, 1218, 2700-2711.
- [55] Smytha, W. F., Rodriguez, V., *Journal of Chromatography A* 2007, 1159, 159-174.
- [56] Pretorius, V., Hopkins, B. J., Schieke, J. D., *Journal of Chromatography A* 1974, 99, 23-30.

- [57] Boone, C. M., Jonkers, E. Z., Franke, J. P., de Zeeuw, R. A., Ensing, K., *Journal of Chromatography A* 2001, 927, 203-210.
- [58] Blas, M., McCord, B. R., *Electrophoresis* 2008, 29, 2182-2192.
- [59] Gusev, I., Huang, X., Horváth, C., *Journal of Chromatography A* 1999, 855, 273-290.
- [60] Svec, F., Peters, E. C., Sýkora, D., Fréchet, J. M. J., *Journal of Chromatography A* 2000, 887, 3-29.
- [61] Svec, F., *Journal of Separation Science* 2005, 28, 729-745.
- [62] Vindevogel, J., Sandra, P., *Electrophoresis* 1994, 15, 842-847.
- [63] World Health Organization, the Annual Report 2012, 2012.
- [64] Levine, B., *Principles of Forensic Toxicology*, American Association for Clinical Chemistry 2010.
- [65] Sue Jickells, A. N., *Clarke's Analytical Forensic Toxicology*, Pharmaceutical Press 2008.
- [66] Khraiwesh, A., Papoutsis, I., Nikolaou, P., Pistos, C., Spiliopoulou, C., Athanaselis, S., *Journal of Chromatography B* 2011, 879, 2576-2582.
- [67] Papoutsis, I., Khraiwesh, A., Nikolaou, P., Pistos, C., Spiliopoulou, C., Athanaselis, S., *Journal of Pharmaceutical and Biomedical Analysis* 2012, 70, 557-562.
- [68] Pietracci, E., Bermejo, A.-M., Álvarez, I., Cabarcos, P., Balduini, W., Taberero, M.-J., *Forensic Toxicol* 2013, 31, 124-132.
- [69] Wille, S. M. R., Van Hee, P., Neels, H. M., Van Peteghem, C. H., Lambert, W. E., *Journal of Chromatography A* 2007, 1176, 236-245.
- [70] Favretto, D., Vogliardi, S., Stocchero, G., Nalesso, A., Tucci, M., Ferrara, S. D., *Journal of Chromatography A* 2011, 1218, 6583-6595.
- [71] Josefsson, M., Roman, M., Skogh, E., Dahl, M.-L., *Journal of Pharmaceutical and Biomedical Analysis* 2010, 53, 576-582.
- [72] Niemi, L. M., Stencel, K. A., Murphy, M. J., Schultz, M. M., *Analytical Chemistry* 2013, 85, 7279-7286.
- [73] Patel, B. N., Sharma, N., Sanyal, M., Shrivastav, P. S., *Journal of Pharmaceutical and Biomedical Analysis* 2008, 47, 603-611.
- [74] Shinozuka, T., Terada, M., Tanaka, E., *Forensic Science International* 2006, 162, 108-112.

- [75] Himmelsbach, M., Buchberger, W., Klampfl, C. W., *Electrophoresis* 2006, 27, 1220-1226.
- [76] Sasajima, Y., Lim, L. W., Takeuchi, T., Suenami, K., Sato, K., Takekoshi, Y., *Journal of Chromatography A* 2010, 1217, 7598-7604.
- [77] Veraart, J. R., Brinkman, U. A. T., *Journal of Chromatography A* 2001, 922, 339-346.
- [78] Hilder, E. F., Svec, F., Fréchet, J. M. J., *Electrophoresis* 2002, 23, 3934-3953.
- [79] Hilder, E. F., Svec, F., Fréchet, J. M. J., *Journal of Chromatography A* 2004, 1044, 3-22.
- [80] Ou, J., Lin, H., Zhang, Z., Huang, G., Dong, J., Zou, H., *Electrophoresis* 2013, 34, 126-140.
- [81] Svec, F., Peters, E. C., Sýkora, D., Yu, C., Fréchet, J. M. J., *Journal of High Resolution Chromatography* 2000, 23, 3-18.
- [82] Wistuba, D., *Journal of Chromatography A* 2010, 1217, 941-952.
- [83] Zhang, Z., Wu, R. a., Wu, M., Zou, H., *Electrophoresis* 2010, 31, 1457-1466.
- [84] Ngola, S. M., Fintschenko, Y., Choi, W.-Y., Shepodd, T. J., *Analytical Chemistry* 2001, 73, 849-856.
- [85] Li, Y., Song, C., Zhang, L., Zhang, W., Fu, H., *Talanta* 2010, 80, 1378-1384.
- [86] Lv, Y., Mei, D., Pan, X., Tan, T., *Journal of Chromatography B* 2010, 878, 2461-2464.
- [87] Hill, S. L., Thomas, S. H. L., *Clinical Toxicology* 2011, 49, 705-719.
- [88] Coppola, M., Mondola, R., *Toxicology Letters* 2012, 211, 144-149.
- [89] Coppola, M., Mondola, R., *Toxicology Letters* 2012, 208, 12-15.
- [90] Centers for Disease Control and Prevention (CDC), U.S. Department of Health and Human Services. *National Vital Statistics Reports Deaths: Final Data for 2007*. Atlanta, GA, USA. 2010.
- [91] Gustavsson, D., Escher, C., *Lakartidningen* 2009, 43, 2769-2771.
- [92] Winstock, A., Mitcheson, L., Marsden, J., *The Lancet* 2010, 376, 1537.
- [93] Wood, D., Davies, S., Puchnarewicz, M., Button, J., Archer, R., Ovaska, H., Ramsey, J., Lee, T., Holt, D., Dargan, P., *J. Med. Toxicol.* 2010, 6, 327-330.

- [94] The Substance Abuse and Mental Health Services Administration (SAMHSA), U.S. Department of Health and Human Services. State Estimates of Substance Use from the 2007-2008 National Survey on Drug Use and Health, Rockville, MD, USA. 2010.
- [95] Brandt, S. D., Sumnall, H. R., Measham, F., Cole, J., *Drug Testing and Analysis* 2010, 2, 377-382.
- [96] Toennes, S. W., Harder, S., Schramm, M., Niess, C., Kauert, G. F., *British Journal of Clinical Pharmacology* 2003, 56, 125-130.
- [97] Prosser, J., Nelson, L., *J. Med. Toxicol.* 2012, 8, 33-42.
- [98] Choi, H. J., Jin, J. S., Hyun, M. H., *Journal of Chromatography B* 2008, 875, 102-107.
- [99] Rasmussen, L. B., Olsen, K. H., Johansen, S. S., *Journal of Chromatography B* 2006, 842, 136-141.
- [100] Jirovský, D., Lemr, K., Ševčík, J., Smysl, B., Stránský, Z., *Forensic Science International* 1998, 96, 61-70.
- [101] Osorio-Olivares, M., Rezende, M. C., Sepúlveda-Boza, S., Cassels, B. K., Baggio, R. F., Muñoz-Acevedo, J. C., *Tetrahedron: Asymmetry* 2003, 14, 1473-1477.
- [102] Swortwood, M., Boland, D., DeCaprio, A., *Anal Bioanal Chem* 2013, 405, 1383-1397.
- [103] Perera, R. W. H., Abraham, I., Gupta, S., Kowalska, P., Lightsey, D., Marathaki, C., Singh, N. S., Lough, W. J., *Journal of Chromatography A* 2012, 1269, 189-197.
- [104] Mohr, S., Taschwer, M., Schmid, M. G., *Chirality* 2012, 24, 486-492.
- [105] Mohr, S., Weiß, J. A., Spreitz, J., Schmid, M. G., *Journal of Chromatography A* 2012, 1269, 352-359.
- [106] Wang, S.-M., Lewis, R. J., Canfield, D., Li, T.-L., Chen, C.-Y., Liu, R. H., *Journal of Chromatography B* 2005, 825, 88-95.
- [107] Mohr, S., Pilaj, S., Schmid, M. G., *Electrophoresis* 2012, 33, 1624-1630.
- [108] Liao, A.-S., Liu, J.-T., Lin, L.-C., Chiu, Y.-C., Shu, Y.-R., Tsai, C.-C., Lin, C.-H., *Forensic Science International* 2003, 134, 17-24.
- [109] Lurie, I. S., Klein, R. F. X., Dal Cason, T. A., LeBelle, M. J., Brenneisen, R., Weinberger, R. E., *Analytical Chemistry* 1994, 66, 4019-4026.
- [110] Maruszak, W., Trojanowicz, M., Margasińska, M., Engelhardt, H., *Journal of Chromatography A* 2001, 926, 327-336.

- [111] Simó, C., García-Cañas, V., Cifuentes, A., *Electrophoresis* 2010, *31*, 1442-1456.
- [112] Li, S. F. Y., *Capillary Electrophoresis*, Elsevier, Amsterdam 1992.
- [113] Fanali, S., *Journal of Chromatography A* 2000, *875*, 89-122.
- [114] Boonleang, J., Stobaugh, J. F., *Electrophoresis* 2013, *34*, 1232-1240.
- [115] Zhang, J., Du, Y., Zhang, Q., Lei, Y., *Talanta* 2014, *119*, 193-201.
- [116] Dixit, S., Park, J. H., *Journal of Chromatography A* 2014, *1326*, 134-138.
- [117] Kuhn, R., Stoecklin, F., Erni, F., *Chromatographia* 1992, *33*, 32-36.
- [118] Kuhn, R., Erni, F., Bereuter, T., Haeusler, J., *Analytical Chemistry* 1992, *64*, 2815-2820.
- [119] Kuhn, R., Riester, D., Fleckenstein, B., Wiesmüller, K.-H., *Journal of Chromatography A* 1995, *716*, 371-379.
- [120] Kuhn, R., Wagner, J., Walbroehl, Y., Bereuter, T., *Electrophoresis* 1994, *15*, 828-834.
- [121] Kuhn, R., Steinmetz, C., Bereuter, T., Haas, P., Erni, F., *Journal of Chromatography A* 1994, *666*, 367-373.
- [122] Castelnovo, P., Albanesi, C., *Journal of Chromatography A* 1995, *715*, 143-149.
- [123] Walbroehl, Y., Wagner, J., *Journal of Chromatography A* 1994, *685*, 321-329.
- [124] Riester, D., Wiesmüller, K.-H., Stoll, D., Kuhn, R., *Analytical Chemistry* 1996, *68*, 2361-2365.
- [125] Walbroehl, Y., Wagner, J., *Journal of Chromatography A* 1994, *680*, 253-261.
- [126] Nishi, H., Nakamura, K., Nakai, H., Sato, T., *Journal of Chromatography A* 1997, *757*, 225-235.
- [127] Mori, Y., Ueno, K., Umeda, T., *Journal of Chromatography A* 1997, *757*, 328-332.
- [128] Thanh Ha, P. T., Van Schepdael, A., Roets, E., Hoogmartens, J., *Journal of Pharmaceutical and Biomedical Analysis* 2004, *34*, 861-870.
- [129] Huang, X., Wang, Q., Huang, B., *Talanta* 2006, *69*, 463-468.
- [130] Jiang, Z., Kang, J., Bischoff, D., Bister, B., Süßmuth, R. D., Schurig, V., *Electrophoresis* 2004, *25*, 2687-2692.

- [131] Kang, J., Wistuba, D., Schurig, V., *Electrophoresis* 2003, 24, 2674-2679.
- [132] Kumar, A. P., Park, J. H., *Journal of Chromatography A* 2011, 1218, 1314-1317.
- [133] Maier, V., Ranc, V., Švidrnoch, M., Petr, J., Ševčík, J., Tesařová, E., Armstrong, D. W., *Journal of Chromatography A* 2012, 1237, 128-132.
- [134] Pormsila, W., Gong, X. Y., Hauser, P. C., *Electrophoresis* 2010, 31, 2044-2048.
- [135] Sánchez-Hernández, L., Crego, A. L., Marina, M. L., García-Ruiz, C., *Electrophoresis* 2008, 29, 237-251.
- [136] Gübitz, G., Schmid, M. G., *Electrophoresis* 2007, 28, 114-126.
- [137] <http://www.sigmaaldrich.com/>. Last access on 16 July 2014.
- [138] Chankvetadze, B., *Electrophoresis* 2009, 30, S211-S221.
- [139] Fornal, E., Stachniuk, A., Wojtyła, A., *Journal of Pharmaceutical and Biomedical Analysis* 2013, 72, 139-144.
- [140] Meyer, M. R., Prosser, D., Maurer, H. H., *Drug Testing and Analysis* 2013, 5, 259-265.
- [141] Favretto, D., Pascali, J. P., Tagliaro, F., *Journal of Chromatography A* 2013, 1287, 84-95.
- [142] Sandra C. Bishop, B. R. M., Samuel R. Gratz, Jill R. Loeliger, and Mark R. Witkowski., *Journal of Forensic Sciences* 2005, 50.
- [143] Molina, M., Wiedmer, S. K., Jussila, M., Silva, M., Riekkola, M.-L., *Journal of Chromatography A* 2001, 927, 191-202.
- [144] Nelson, W. M., Tang, Q., Harrata, A. K., Lee, C. S., *Journal of Chromatography A* 1996, 749, 219-226.
- [145] Tanaka, Y., Otsuka, K., Terabe, S., *Journal of Chromatography A* 2000, 875, 323-330.
- [146] Sánchez-Hernández, L., Serra, N. S., Marina, M. L., Crego, A. L., *Journal of Agricultural and Food Chemistry* 2013, 61, 5022-5030.
- [147] Awad, H., El-Aneed, A., *Mass Spectrometry Reviews* 2013, 32, 466-483.
- [148] Wuethrich, A., Haddad, P. R., Quirino, J. P., *Electrophoresis* 2014, 35, 2-11.
- [149] McMaster, M. C., *LC/MS: A Practical User's Guide*, John Wiley & Sons, Inc. 2005.

- [150] Smith, R. D., Barinaga, C. J., Udseth, H. R., *Analytical Chemistry* 1988, 60, 1948-1952.
- [151] Foret, F., Thompson, T. J., Vouros, P., Karger, B. L., Gebauer, P., Bocek, P., *Analytical Chemistry* 1994, 66, 4450-4458.
- [152] Valtcheva, L., Mohammad, J., Pettersson, G., Hjertén, S., *Journal of Chromatography A* 1993, 638, 263-267.
- [153] Hudson, J. C., *Beckman Coulter Technical Note: Rapid Enantiomeric Separation of 101 Basic Drugs and Metabolites: A Generic Strategy Using Highly Sulfated Cyclodextrins*.
- [154] Hudson, J. C., *Beckman Coulter Technical Note: Analysis of Methamphetamine and Its Metabolite, Amphetamine by Chiral CESI-MS*.
- [155] Dubský, P., Svobodová, J., Tesařová, E., Gaš, B., *Electrophoresis* 2010, 31, 1435-1441.
- [156] Iwata, Y. T., Kanamori, T., Ohmae, Y., Tsujikawa, K., Inoue, H., Kishi, T., *Electrophoresis* 2003, 24, 1770-1776.
- [157] Substance Abuse and Mental Health Services Administration, U. S. D. o. H. a. H. S., 2010.
- [158] The 2013 Florida Statutes, TITLE XLVI Chapter 893.03.
- [159] Anagnostidis, K., Komárek, J. í., *Algological Studies/Archiv für Hydrobiologie, Supplement Volumes* 1985, 38-39, 291-302.
- [160] Komárek, J. í., Anagnostidis, K., *Algological Studies/Archiv für Hydrobiologie, Supplement Volumes* 1989, 56, 247-345.
- [161] Anagnostidis, K., Komárek, J. í., *Algological Studies/Archiv für Hydrobiologie, Supplement Volumes* 1990, 59, 1-73.
- [162] Price, G. D., Badger, M. R., Woodger, F. J., Long, B. M., *Journal of Experimental Botany* 2008, 59, 1441-1461.
- [163] Freitas de Magalhães, V., Moraes Soares, R., Azevedo, S. M. F. O., *Toxicon* 2001, 39, 1077-1085.
- [164] Dantas, Ê. W., Moura, A. d. N., Bittencourt-Oliveira, M. d. C., Arruda Neto, J. D. d. T., Cavalcanti, A. d. D. C., *Acta Botanica Brasilica* 2008, 22, 970-982.
- [165] Stewart, I., Webb, P., Schluter, P., Fleming, L., Burns, J., Gantar, M., Backer, L., Shaw, G., *BMC Public Health* 2006, 6, 93.

- [166] Stewart, I., Schluter, P., Shaw, G., *Environmental Health: A Global Access Science Source* 2006, 5, 7.
- [167] Carmichael Wayne, W., Mahmood Nik, A., Hyde Edward, G., *Marine Toxins*, American Chemical Society 1990, pp. 87-106.
- [168] Carmichael, W. W., *Journal of Applied Bacteriology* 1992, 72, 445-459.
- [169] Voloshko, L., Kopecky, J., Safronova, T., Pljusich, A., Titova, N., Hrouzek, P., Drabkova, V., *Estonian Journal of Ecology* 2008, 57, 100-110.
- [170] Adamson, R. H., Chabner, B., Fujiki, H., *Cancer Science* 1989, 80, 1141-1144.
- [171] Ibelings, B., Havens, K., in: Hudnell, H. K. (Ed.), *Cyanobacterial Harmful Algal Blooms: State of the Science and Research Needs*, Springer New York 2008, pp. 675-732.
- [172] Chen, W., Song, L., Ou, D., Gan, N., *Environmental Toxicology* 2005, 20, 323-330.
- [173] Tencalla, F. G., Dietrich, D. R., Schlatter, C., *Aquatic Toxicology* 1994, 30, 215-224.
- [174] World Health Organization, the Annual Report 1997, 1997.
- [175] Azevedo, S. M. F. O., Carmichael, W. W., Jochimsen, E. M., Rinehart, K. L., Lau, S., Shaw, G. R., Eaglesham, G. K., *Toxicology* 2002, 181-182, 441-446.
- [176] Nicholson, B. C., Rositano, J., Burch, M. D., *Water Research* 1994, 28, 1297-1303.
- [177] Robillot, C., Vinh, J., Puiseux-Dao, S., Hennion, M.-C., *Environmental Science & Technology* 2000, 34, 3372-3378.
- [178] Babica, P., Kohoutek, J., Bláha, L., Adamovský, O., Maršálek, B., *Anal Bioanal Chem* 2006, 385, 1545-1551.
- [179] Ikawa, M., Phillips, N., Haney, J. F., Sasner, J. J., *Toxicon* 1999, 37, 923-929.
- [180] Sangolkar, L. N., Maske, S. S., Chakrabarti, T., *Water Research* 2006, 40, 3485-3496.
- [181] Harada, K.-I., Murata, H., Qiang, Z., Suzuki, M., Kondo, F., *Toxicon* 1996, 34, 701-710.
- [182] Kaya, K., Sano, T., *Analytica Chimica Acta* 1999, 386, 107-112.
- [183] Kondo, F., Ito, Y., Oka, H., Yamada, S., Tsuji, K., Imokawa, M., Niimi, Y., Harada, K.-i., Ueno, Y., Miyazaki, Y., *Toxicon* 2002, 40, 893-899.

- [184] Al-Layl, K. J., Poo, G. K., Codd, G. A., *Journal of Microbiological Methods* 1988, 7, 251-257.
- [185] Pelander, A., Ojanperä, I., Sivonen, K., Himberg, K., Waris, M., Niinivaara, K., Vuori, E., *Water Research* 1996, 30, 1464-1470.
- [186] Pelander, A., Ojanperä, I., Lahti, K., Niinivaara, K., Vuori, E., *Water Research* 2000, 34, 2643-2652.
- [187] McElhiney, J., Lawton, L. A., *Toxicology and Applied Pharmacology* 2005, 203, 219-230.
- [188] Sirén, H., Jussila, M., Liu, H., Peltoniemi, S., Sivonen, K., Riekkola, M.-L., *Journal of Chromatography A* 1999, 839, 203-215.
- [189] Gago-Martínez, A., Piñeiro, N., Agüete, E. C., Vaquero, E., Nogueiras, M., Leão, J. M., Rodríguez-Vázquez, J. A., Dabek-Zlotorzynska, E., *Journal of Chromatography A* 2003, 992, 159-168.
- [190] Zeisbergerová, M., Košťál, V., Šrámková, M., Babica, P., Bláha, L., Glatz, Z., Kahle, V., *Journal of Chromatography B* 2006, 841, 140-144.
- [191] Vasas, G., Gáspár, A., Páger, C., Surányi, G., Máthé, C., Hamvas, M. M., Borbely, G., *Electrophoresis* 2004, 25, 108-115.
- [192] Agüete, E. C., Gago-Martínez, A., Leão, J. M., Rodríguez-Vázquez, J. A., Menàrd, C., Lawrence, J. F., *Talanta* 2003, 59, 697-705.
- [193] Zheng, B., Master's Thesis, Florida International University, Miami 2014.
- [194] Spooft, L., Vesterkvist, P., Lindholm, T., Meriluoto, J., *Journal of Chromatography A* 2003, 1020, 105-119.
- [195] Welker, M., Brunke, M., Preussel, K., Lippert, I., von Döhren, H., *Microbiology* 2004, 150, 1785-1796.
- [196] Dahlmann, J., Budakowski, W. R., Luckas, B., *Journal of Chromatography A* 2003, 994, 45-57.
- [197] Cong, L., Huang, B., Chen, Q., Lu, B., Zhang, J., Ren, Y., *Analytica Chimica Acta* 2006, 569, 157-168.
- [198] Smith, S. W., *Toxicol. Sci.* 2009, 110, 4-30.
- [199] Schurig, V., Mayer, S., *Journal of Biochemical and Biophysical Methods* 2001, 48, 117-141.

- [200] Schurig, V., Schmalzing, D., Mühleck, U., Jung, M., Schleimer, M., Mussche, P., Duvekot, C., Buyten, J. C., *Journal of High Resolution Chromatography* 1990, 13, 713-717.
- [201] Schurig, V., Schmalzing, D., Schleimer, M., *Angewandte Chemie International Edition in English* 1991, 30, 987-989.
- [202] Schurig, V., Juvancz, Z., Nicholson, G. J., Schmalzing, D., *Journal of High Resolution Chromatography* 1991, 14, 58-62.
- [203] Throckmorton, D. J., Shepodd, T. J., Singh, A. K., *Analytical Chemistry* 2002, 74, 784-789.
- [204] Ouyang, Z., Cooks, R. G., *Annual Review of Analytical Chemistry* 2009, 2, 187-214.
- [205] Drew, R. C., Kuehn, T. J., US Patent 20090312190 A1. 1994.
- [206] Culbertson, C. T., Mickleburgh, T. G., Stewart-James, S. A., Sellens, K. A., Pressnall, M., *Analytical Chemistry* 2013, 86, 95-118.
- [207] Ericson, C., Holm, J., Ericson, T., Hjertén, S., *Analytical Chemistry* 1999, 72, 81-87.
- [208] Knox, J. H., Parcher, J. F., *Analytical Chemistry* 1969, 41, 1599-1606.
- [209] Shediak, R., Ngola, S. M., Throckmorton, D. J., Anex, D. S., Shepodd, T. J., Singh, A. K., *Journal of Chromatography A* 2001, 925, 251-263.
- [210] Lazar, I. M., Li, L., Yang, Y., Karger, B. L., *Electrophoresis* 2003, 24, 3655-3662.
- [211] Dulay, M. T., Quirino, J. P., Bennett, B. D., Kato, M., Zare, R. N., *Analytical Chemistry* 2001, 73, 3921-3926.
- [212] Morishima, K., Bennett, B. D., Dulay, M. T., Quirino, J. P., Zare, R. N., *Journal of Separation Science* 2002, 25, 1226-1230.
- [213] Dixit, S., Park, J. H., *Biomedical Chromatography* 2014, 28, 10-26.
- [214] Prokhorova, A. F., Shapovalova, E. N., Shpigun, O. A., *Journal of Pharmaceutical and Biomedical Analysis* 2010, 53, 1170-1179.
- [215] Kuhn, R., *Electrophoresis* 1999, 20, 2605-2613.
- [216] Schmid, M. G., Gübitz, G., *Journal of Chromatography A* 1995, 709, 81-88.
- [217] Yu, T., Du, Y., Chen, B., *Electrophoresis* 2011, 32, 1898-1905.
- [218] Chen, B., Du, Y., Li, P., *Electrophoresis* 2009, 30, 2747-2754.

APPENDICES

I. In situ synthesis of monolithic stationary phases for electrochromatographic separations

1. Capillary pretreatment

Cut a 100 μm I.D. transparent capillary to the required length, i.e. 80 cm. Rinse the capillary based on the following order.

- Acetone – 5 min
- NaOH – 60 min
- 6 mM acetic acid* containing 4 μL of trimethoxysilylpropyl acrylate (TMSA) – 10 min
- Static mode – 60 min
- H₂O – 30 min
- N₂ – 15 min (Use an empty vial at inlet)

* 6 mM acetic acid: Add 34 μL glacial acetic acid to deionized water, total vol. 100 mL.

2. Preparation of the polymerization mixture.

Polymerization solution consists of a mixture of a monomer mixture (A) with 4mL of the porogenic solvent (B).

A. consists of a mixture which contain hexyl acrylate (76%, 1369 μL); 1,3-butanediol diacrylate (24%, 591 μL) ; 2-acrylamido-2-methyl-1-propanesulfonicacid (0.5%, 14.5mg) and trimethoxysilylpropyl acrylate (2 μL)

B. a mixture of Ethanol, Phosphate Buffer (pH6.8, 5mM), and Acetonitrile (v/v/v=1/1/3, i.e. 2 mL/2 mL/6 mL)

Phosphate buffer: 0.0371 g of monosodium phosphate, monohydrate and 0.062 g of Disodium phosphate, heptahydrate in 100 mL deionized water.

AIBN (0.5 % with respect to monomer, 9.4mg) is added to the polymerization solution as initiator. The polymerization solution is then sonicated to obtain a clear solution and to remove dissolved air. The solution MUST be clear.

3. Monolithic column

i. Filling

The capillary is filled with the polymerization mixture by immersing the inlet of the capillary into a reservoir and by pushing the polymerization solution under gas pressure. After 30 min, its ends are sealed.

ii. Polymerization

The capillary is then placed into an UV oven 365nm during 1h at room temperature. Then 2cm of both ends are cut and the capillary is put in the CE instrument. The monolith must be present in the entire capillary.

iii. Washing (Post-treatment)

Before any analysis, a voltage program ranging from 0 to 20kV in 120 min with a total duration of 300min is applied on the capillary with a mobile phase which consists of a mixture Acetonitrile/Phosphate Buffer pH6.8 (80/20). A pressure of 5 bar provided by

pressurized nitrogen is applied at both ends of the capillary during every experimental runs to minimize bubble formation. A detection window is created on the column as a result of exposure to the deuterium light of the detector. At the end of the conditioning the UV noise must be around 0.1mAU, and a stable current around 2-4uA (30kV applied) must be observed.

II. Instructional guidelines for the usage of the Agilent Chem Station in CE/CEC mode.

1. Disconnect CE with TOF-MS. See diagram on the back of the MS for details.
2. Turn on CE. The ON/OFF switch is on the lower left side of the front panel.
3. Start the Agilent ChemStation (Instrument 1 Online)
 - a. Go to menu bar. Select Instrument.
 - Select system INIT
 - b. Wait for ready (Green light in the status bar of the software)
 - c. Click on Run method
4. If you plan to not use the instruments for a few hours:
 - Turn off the CE lamp
5. At the end of the day:
 - a. Turn off the CE lamp
 - b. Close ChemStation software
 - c. Turn off the CE

**JOHN WILEY AND SONS LICENSE
TERMS AND CONDITIONS**

Jul 25, 2014

This is a License Agreement between Hanzhuo Fu ("You") and John Wiley and Sons ("John Wiley and Sons") provided by Copyright Clearance Center ("CCC"). The license consists of your order details, the terms and conditions provided by John Wiley and Sons, and the payment terms and conditions.

All payments must be made in full to CCC. For payment instructions, please see information listed at the bottom of this form.

License Number	3431710745646
License date	Jul 18, 2014
Licensed content publisher	John Wiley and Sons
Licensed content publication	Electrophoresis
Licensed content title	Chiral separation of 12 cathinone analogs by cyclodextrin-assisted capillary electrophoresis with UV and mass spectrometry detection
Licensed copyright line	© 2014 WILEY-VCH Verlag GmbH & Co. KGaA, Weinheim
Licensed content author	Gustavo Merola,Hanzhuo Fu,Franco Tagliaro,Teodora Macchia,Bruce R. McCord
Licensed content date	Jun 20, 2014
Start page	n/a
End page	n/a
Type of use	Dissertation/Thesis
Requestor type	Author of this Wiley article
Format	Print and electronic
Portion	Full article
Will you be translating?	No
Title of your thesis / dissertation	DEVELOPMENT OF ADVANCED CAPILLARY ELECTROPHORESIS TECHNIQUES WITH UV AND MASS SPECTROMETRY DETECTION FOR FORENSIC, PHARMACEUTICAL AND ENVIRONMENTAL APPLICATIONS
Expected completion date	Aug 2014
Expected size (number of pages)	130
Total	0.00 USD
Terms and Conditions	

TERMS AND CONDITIONS

This copyrighted material is owned by or exclusively licensed to John Wiley & Sons, Inc. or one of its group companies (each a "Wiley Company") or handled on behalf of a society with

<https://s100.copyright.com/CustomerAdmin/PLF.jsp?ref=523b2ee9-c688-41d2-9106-04ed865d8887>

which a Wiley Company has exclusive publishing rights in relation to a particular work (collectively "WILEY"). By clicking accept in connection with completing this licensing transaction, you agree that the following terms and conditions apply to this transaction (along with the billing and payment terms and conditions established by the Copyright Clearance Center Inc., ("CCC's Billing and Payment terms and conditions"), at the time that you opened your Rightslink account (these are available at any time at <http://myaccount.copyright.com>).

Terms and Conditions

- The materials you have requested permission to reproduce or reuse (the "Wiley Materials") are protected by copyright.
- You are hereby granted a personal, non-exclusive, non-sub licensable (on a stand-alone basis), non-transferable, worldwide, limited license to reproduce the Wiley Materials for the purpose specified in the licensing process. This license is for a one-time use only and limited to any maximum distribution number specified in the license. The first instance of republication or reuse granted by this licence must be completed within two years of the date of the grant of this licence (although copies prepared before the end date may be distributed thereafter). The Wiley Materials shall not be used in any other manner or for any other purpose, beyond what is granted in the license. Permission is granted subject to an appropriate acknowledgement given to the author, title of the material/book/journal and the publisher. You shall also duplicate the copyright notice that appears in the Wiley publication in your use of the Wiley Material. Permission is also granted on the understanding that nowhere in the text is a previously published source acknowledged for all or part of this Wiley Material. Any third party content is expressly excluded from this permission.
- With respect to the Wiley Materials, all rights are reserved. Except as expressly granted by the terms of the license, no part of the Wiley Materials may be copied, modified, adapted (except for minor reformatting required by the new Publication), translated, reproduced, transferred or distributed, in any form or by any means, and no derivative works may be made based on the Wiley Materials without the prior permission of the respective copyright owner. You may not alter, remove or suppress in any manner any copyright, trademark or other notices displayed by the Wiley Materials. You may not license, rent, sell, loan, lease, pledge, offer as security, transfer or assign the Wiley Materials on a stand-alone basis, or any of the rights granted to you hereunder to any other person.
- The Wiley Materials and all of the intellectual property rights therein shall at all times remain the exclusive property of John Wiley & Sons Inc, the Wiley Companies, or their respective licensors, and your interest therein is only that of having possession of and the right to reproduce the Wiley Materials pursuant to Section 2 herein during the continuance of this Agreement. You agree that you own no right, title or interest in or to the Wiley Materials or any of the intellectual property rights therein. You shall have no rights hereunder other than the license as provided for above in Section 2. No right, license or interest to any trademark, trade name, service mark or other branding ("Marks") of WILEY or its licensors is granted hereunder, and you agree that you shall not assert any such right, license or interest with respect thereto.
- NEITHER WILEY NOR ITS LICENSORS MAKES ANY WARRANTY OR

<https://s100.copyright.com/CustomerAdmin/PLF.jsp?ref=523b2ee9-c688-41d2-9106-04ed865d8887>

REPRESENTATION OF ANY KIND TO YOU OR ANY THIRD PARTY, EXPRESS, IMPLIED OR STATUTORY, WITH RESPECT TO THE MATERIALS OR THE ACCURACY OF ANY INFORMATION CONTAINED IN THE MATERIALS, INCLUDING, WITHOUT LIMITATION, ANY IMPLIED WARRANTY OF MERCHANTABILITY, ACCURACY, SATISFACTORY QUALITY, FITNESS FOR A PARTICULAR PURPOSE, USABILITY, INTEGRATION OR NON-INFRINGEMENT AND ALL SUCH WARRANTIES ARE HEREBY EXCLUDED BY WILEY AND ITS LICENSORS AND WAIVED BY YOU

- WILEY shall have the right to terminate this Agreement immediately upon breach of this Agreement by you.
- You shall indemnify, defend and hold harmless WILEY, its Licensors and their respective directors, officers, agents and employees, from and against any actual or threatened claims, demands, causes of action or proceedings arising from any breach of this Agreement by you.
- IN NO EVENT SHALL WILEY OR ITS LICENSORS BE LIABLE TO YOU OR ANY OTHER PARTY OR ANY OTHER PERSON OR ENTITY FOR ANY SPECIAL, CONSEQUENTIAL, INCIDENTAL, INDIRECT, EXEMPLARY OR PUNITIVE DAMAGES, HOWEVER CAUSED, ARISING OUT OF OR IN CONNECTION WITH THE DOWNLOADING, PROVISIONING, VIEWING OR USE OF THE MATERIALS REGARDLESS OF THE FORM OF ACTION, WHETHER FOR BREACH OF CONTRACT, BREACH OF WARRANTY, TORT, NEGLIGENCE, INFRINGEMENT OR OTHERWISE (INCLUDING, WITHOUT LIMITATION, DAMAGES BASED ON LOSS OF PROFITS, DATA, FILES, USE, BUSINESS OPPORTUNITY OR CLAIMS OF THIRD PARTIES), AND WHETHER OR NOT THE PARTY HAS BEEN ADVISED OF THE POSSIBILITY OF SUCH DAMAGES. THIS LIMITATION SHALL APPLY NOTWITHSTANDING ANY FAILURE OF ESSENTIAL PURPOSE OF ANY LIMITED REMEDY PROVIDED HEREIN.
- Should any provision of this Agreement be held by a court of competent jurisdiction to be illegal, invalid, or unenforceable, that provision shall be deemed amended to achieve as nearly as possible the same economic effect as the original provision, and the legality, validity and enforceability of the remaining provisions of this Agreement shall not be affected or impaired thereby.
- The failure of either party to enforce any term or condition of this Agreement shall not constitute a waiver of either party's right to enforce each and every term and condition of this Agreement. No breach under this agreement shall be deemed waived or excused by either party unless such waiver or consent is in writing signed by the party granting such waiver or consent. The waiver by or consent of a party to a breach of any provision of this Agreement shall not operate or be construed as a waiver of or consent to any other or subsequent breach by such other party.
- This Agreement may not be assigned (including by operation of law or otherwise) by you without WILEY's prior written consent.
- Any fee required for this permission shall be non-refundable after thirty (30) days from

receipt by the CCC.

- These terms and conditions together with CCC's Billing and Payment terms and conditions (which are incorporated herein) form the entire agreement between you and WILEY concerning this licensing transaction and (in the absence of fraud) supersedes all prior agreements and representations of the parties, oral or written. This Agreement may not be amended except in writing signed by both parties. This Agreement shall be binding upon and inure to the benefit of the parties' successors, legal representatives, and authorized assigns.
- In the event of any conflict between your obligations established by these terms and conditions and those established by CCC's Billing and Payment terms and conditions, these terms and conditions shall prevail.
- WILEY expressly reserves all rights not specifically granted in the combination of (i) the license details provided by you and accepted in the course of this licensing transaction, (ii) these terms and conditions and (iii) CCC's Billing and Payment terms and conditions.
- This Agreement will be void if the Type of Use, Format, Circulation, or Requestor Type was misrepresented during the licensing process.
- This Agreement shall be governed by and construed in accordance with the laws of the State of New York, USA, without regards to such state's conflict of law rules. Any legal action, suit or proceeding arising out of or relating to these Terms and Conditions or the breach thereof shall be instituted in a court of competent jurisdiction in New York County in the State of New York in the United States of America and each party hereby consents and submits to the personal jurisdiction of such court, waives any objection to venue in such court and consents to service of process by registered or certified mail, return receipt requested, at the last known address of such party.

WILEY OPEN ACCESS TERMS AND CONDITIONS

Wiley Publishes Open Access Articles in fully Open Access Journals and in Subscription journals offering Online Open. Although most of the fully Open Access journals publish open access articles under the terms of the Creative Commons Attribution (CC BY) License only, the subscription journals and a few of the Open Access Journals offer a choice of Creative Commons Licenses: Creative Commons Attribution (CC-BY) license [Creative Commons Attribution Non-Commercial \(CC-BY-NC\) license](#) and [Creative Commons Attribution Non-Commercial-NoDerivs \(CC-BY-NC-ND\) License](#). The license type is clearly identified on the article.

Copyright in any research article in a journal published as Open Access under a Creative Commons License is retained by the author(s). Authors grant Wiley a license to publish the article and identify itself as the original publisher. Authors also grant any third party the right to use the article freely as long as its integrity is maintained and its original authors, citation details and publisher are identified as follows: [Title of Article/Author/Journal Title and Volume/Issue. Copyright (c) [year] [copyright owner as specified in the Journal]. Links to the final article on Wiley's website are encouraged where applicable.

The Creative Commons Attribution License

The [Creative Commons Attribution License \(CC-BY\)](#) allows users to copy, distribute and transmit an article, adapt the article and make commercial use of the article. The CC-BY license permits commercial and non-commercial re-use of an open access article, as long as the author is properly attributed.

The Creative Commons Attribution License does not affect the moral rights of authors, including without limitation the right not to have their work subjected to derogatory treatment. It also does not affect any other rights held by authors or third parties in the article, including without limitation the rights of privacy and publicity. Use of the article must not assert or imply, whether implicitly or explicitly, any connection with, endorsement or sponsorship of such use by the author, publisher or any other party associated with the article.

For any reuse or distribution, users must include the copyright notice and make clear to others that the article is made available under a Creative Commons Attribution license, linking to the relevant Creative Commons web page.

To the fullest extent permitted by applicable law, the article is made available as is and without representation or warranties of any kind whether express, implied, statutory or otherwise and including, without limitation, warranties of title, merchantability, fitness for a particular purpose, non-infringement, absence of defects, accuracy, or the presence or absence of errors.

Creative Commons Attribution Non-Commercial License

The [Creative Commons Attribution Non-Commercial \(CC-BY-NC\) License](#) permits use, distribution and reproduction in any medium, provided the original work is properly cited and is not used for commercial purposes.(see below)

Creative Commons Attribution-Non-Commercial-NoDerivs License

The [Creative Commons Attribution Non-Commercial-NoDerivs License](#) (CC-BY-NC-ND) permits use, distribution and reproduction in any medium, provided the original work is properly cited, is not used for commercial purposes and no modifications or adaptations are made. (see below)

Use by non-commercial users

For non-commercial and non-promotional purposes, individual users may access, download, copy, display and redistribute to colleagues Wiley Open Access articles, as well as adapt, translate, text- and data-mine the content subject to the following conditions:

- The authors' moral rights are not compromised. These rights include the right of "paternity" (also known as "attribution" - the right for the author to be identified as such) and "integrity" (the right for the author not to have the work altered in such a way that the author's reputation or integrity may be impugned).
- Where content in the article is identified as belonging to a third party, it is the obligation of the user to ensure that any reuse complies with the copyright policies of the owner of that content.
- If article content is copied, downloaded or otherwise reused for non-commercial

research and education purposes, a link to the appropriate bibliographic citation (authors, journal, article title, volume, issue, page numbers, DOI and the link to the definitive published version on **Wiley Online Library**) should be maintained. Copyright notices and disclaimers must not be deleted.

- Any translations, for which a prior translation agreement with Wiley has not been agreed, must prominently display the statement: "This is an unofficial translation of an article that appeared in a Wiley publication. The publisher has not endorsed this translation."

Use by commercial "for-profit" organisations

Use of Wiley Open Access articles for commercial, promotional, or marketing purposes requires further explicit permission from Wiley and will be subject to a fee. Commercial purposes include:

- Copying or downloading of articles, or linking to such articles for further redistribution, sale or licensing;
- Copying, downloading or posting by a site or service that incorporates advertising with such content;
- The inclusion or incorporation of article content in other works or services (other than normal quotations with an appropriate citation) that is then available for sale or licensing, for a fee (for example, a compilation produced for marketing purposes, inclusion in a sales pack)
- Use of article content (other than normal quotations with appropriate citation) by for-profit organisations for promotional purposes
- Linking to article content in e-mails redistributed for promotional, marketing or educational purposes;
- Use for the purposes of monetary reward by means of sale, resale, licence, loan, transfer or other form of commercial exploitation such as marketing products
- Print reprints of Wiley Open Access articles can be purchased from: corporatesales@wiley.com

Further details can be found on Wiley Online Library
<http://olabout.wiley.com/WileyCDA/Section/id-410895.html>

Other Terms and Conditions:

v1.9

If you would like to pay for this license now, please remit this license along with your payment made payable to "COPYRIGHT CLEARANCE CENTER" otherwise you will be invoiced within 48 hours of the license date. Payment should be in the form of a check or money order referencing your account number and this invoice number 501354754. Once you receive your invoice for this order, you may pay your invoice by credit card. Please follow instructions provided at that time.

**Make Payment To:
Copyright Clearance Center
Dept 001
P.O. Box 843006
Boston, MA 02284-3006**

For suggestions or comments regarding this order, contact RightsLink Customer Support: customercare@copyright.com or +1-877-622-5543 (toll free in the US) or +1-978-646-2777.

Gratis licenses (referencing \$0 in the Total field) are free. Please retain this printable license for your reference. No payment is required.

VITA

HANZHUO FU

- 2007 Intern
Quality Control Department
Yulin Natural Gas Chemical Industry Co.,LTD,
Yulin, China
- 2008 -2009 Undergraduate Researcher
Dr. Lili Wang Group, Bio-analytical Lab
Northwest University
Xi'an, China
- 2009 B.S., Chemistry
Northwest University
Xi'an, China
- 2009-2014 Graduate Teaching Assistant
Florida International University
Miami, FL, USA
- 2009-2014 Doctoral Candidate
Dr. McCord Group, Analytical / Forensic Toxicology
Florida International University
Miami, FL, USA

PUBLICATIONS AND PRESENTATIONS

Merola, G.[#], Fu, H.[#] ([#] co-first authors), Tagliaro, F., Macchia, T., and McCord, B. R. Chiral separation of 12 cathinone analogs by cyclodextrin-assisted capillary electrophoresis with UV and mass spectrometry detection. *Electrophoresis*, 2014. In press. DOI 10.1002/elps.201400077.

Fu, H. and McCord, B. R. Separation and identification of antidepressants by acrylate-based monolith column capillary electrochromatography with UV detection and urine sample extraction. In preparation.

Zheng, B., Fu, H., McCord, B. R., and Berry, J. A novel method for rapid separation and detection of microcystins by capillary electrophoresis mass spectrometry. In preparation.

Yang, D., Li, Z., Diwu, Y. A., Fu, H., Liao, J., Wei, C. and Diwu, Z. A Novel Fluorogenic Coumarin Substrate for Monitoring Acid Phosphatase Activity at Low pH Environment. *Current Chemical Genomics* 2008, 2, 48-50.

Fu, H. and McCord, B.R. Capillary Electrophoresis Mass Spectrometry. FIU Research Experience for Undergraduates (REU) Summer Research Series. Invited Talk. June 10, 2014. Miami, Florida.

Fu, H., Merola, G., Tagliaro, F., Macchia, T., and McCord, B. R. Chiral separation of 12 cathinone analogs by cyclodextrin-assisted capillary electrophoresis with UV and mass spectrometry detection. The 41st International Symposium on High Performance Liquid Phase Separations and Related Techniques (HPLC 2014). May 13th, 2014. New Orleans, LA.

Fu, H., Merola, G., Tagliaro, F., Macchia, T., and McCord, B. R. Simultaneous chiral separation of 12 cathinone analogs by cyclodextrin-assisted capillary electrophoresis mass spectrometry. IFRI Third Annual Forensic Science Symposium. April 30, 2014. Miami, Florida.

Fu, H. and McCord, B. R. Separation and identification of select drugs by monolith capillary electrochromatography. The 245th American Chemical Society (ACS) National Meeting. April 8, 2013 New Orleans, Louisiana.

Fu, H. and McCord, B. R. Capillary electrophoresis and capillary electrochromatography mass spectrometry for detection of charged and neutral drugs. The 38th International Symposium on High Performance Liquid Phase Separations and Related Techniques (HPLC 2012). June 19, 2012. Anaheim, Californian.

Fu, H. and McCord, B. R. Capillary electrophoresis and capillary electrochromatography mass spectrometry for chiral drug detection. The 64th American Academy of Forensic Sciences (AAFS) Annual Meeting. Feb 22, 2012. Atlanta, Georgia.

Fu, H. and McCord, B. R. Capillary electrophoresis and capillary electrochromatography mass spectrometry for chiral drug detection. Department of Chemistry Graduate Visitation Day. Mar 4, 2011. F.I.U, Miami, Florida.